

## Scratch-Build the ME-262-V1

**1941 ME-262-V1**  
 piston power test for Jet ME-262-V2

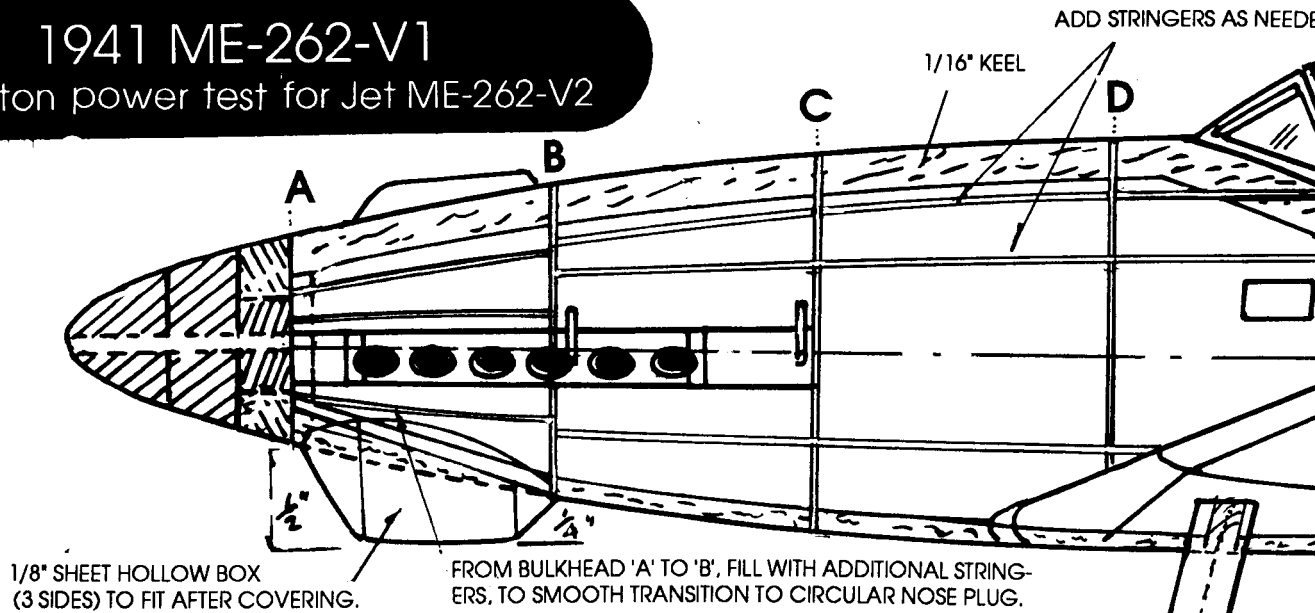

*From reader E.J. "Sig Stigmon, these interesting drawings of the piston power test bed ME-262 V1, the forerunner to the twin jet Jumo powered ME-262 V2. We re-inked the drawings from Sig's penciled drawings. There is not much detail here, however, Sig built a successful flying model and we think you can also. So, scratch builders, go to it. You can write Sig at 5825 Lowell Rd., Everett, WA 98203.*

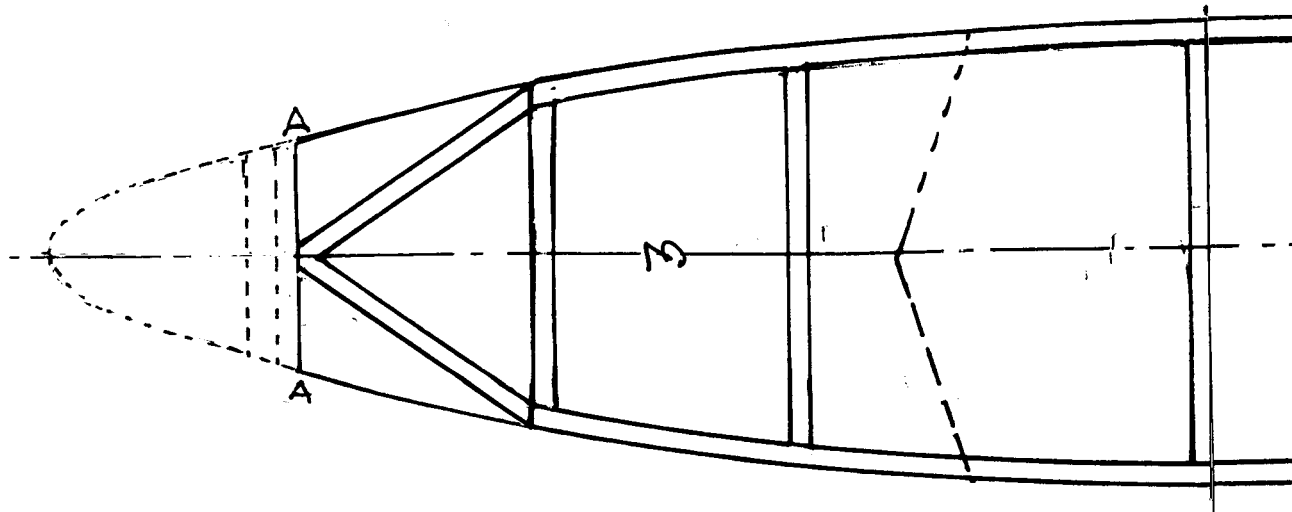

NGERS AS NEEDED.

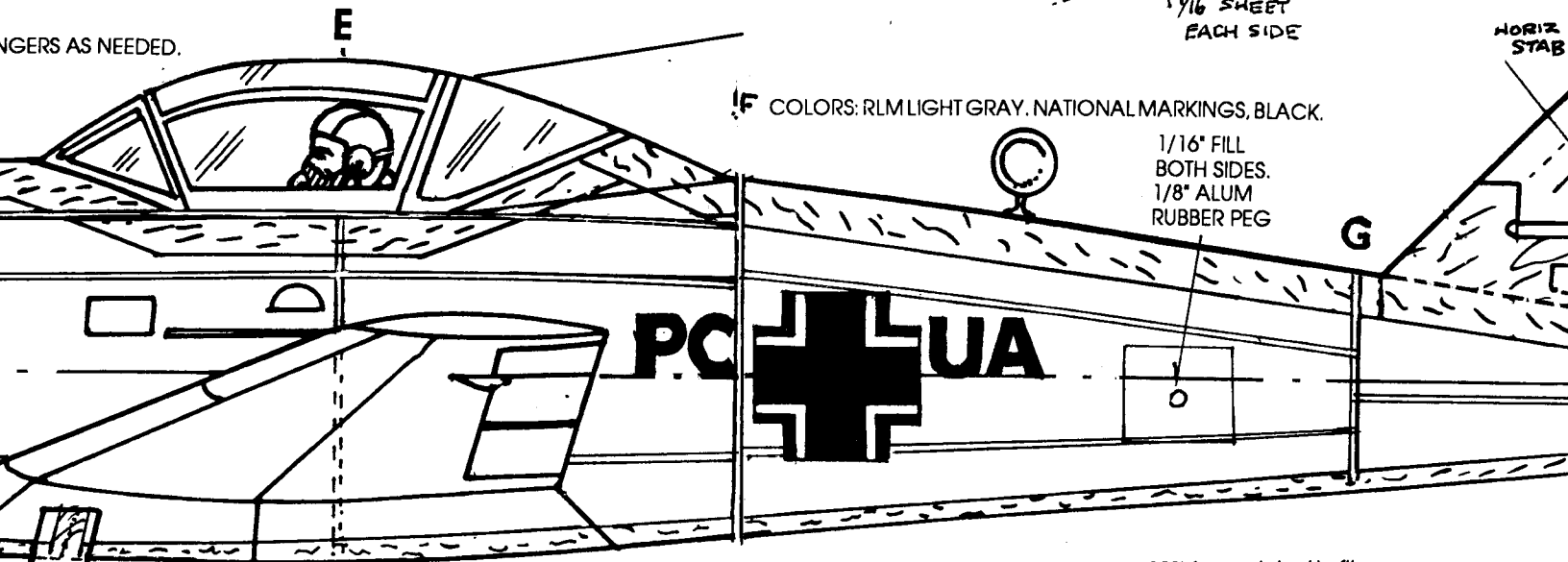

F COLORS: RLM LIGHT GRAY, NATIONAL MARKINGS, BLACK.

1/16" FILL  
BOTH SIDES.  
1/8" ALUM  
RUBBER PEG

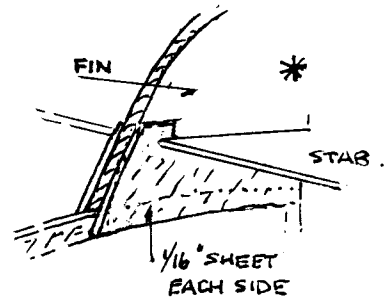

HORIZ  
STAB

*These drawings reduced 10% from original to fit our pages.  
Build this size or enlarge with copier.*

ME-262-V1  
DESIGNED BUILT FLOWN  
AS STAND-OFF SCALE IN  
"NO-DOC" FUN FLT CONTEST

"DON'T FORGET THE PILOT"

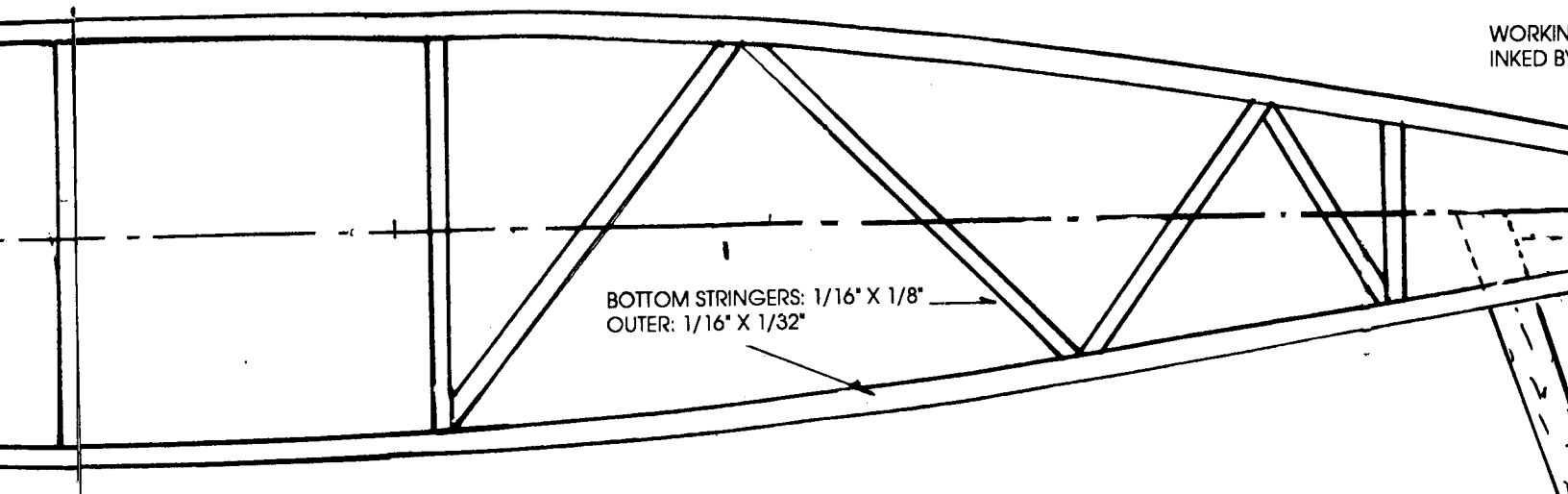

BOTTOM STRINGERS: 1/16" X 1/8"  
OUTER: 1/16" X 1/32"

WORKIN  
INKED BY

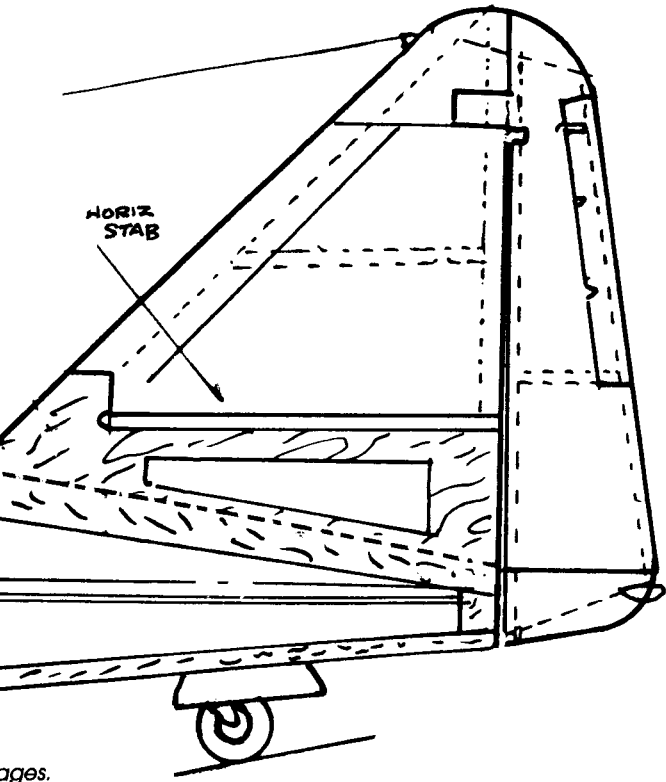

ages.

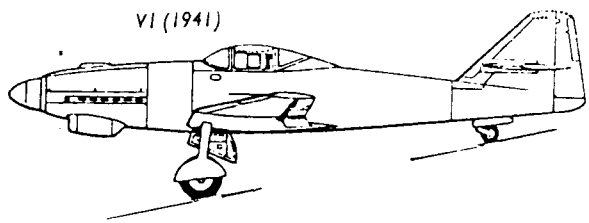

WORKING DRAWINGS BY E.J. "SIG" SIGMON.  
INKED BY FRANK MEAD.

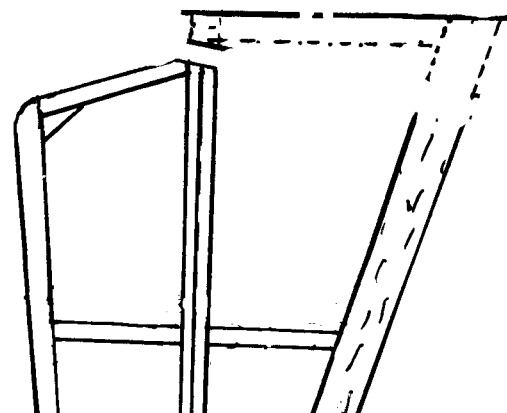
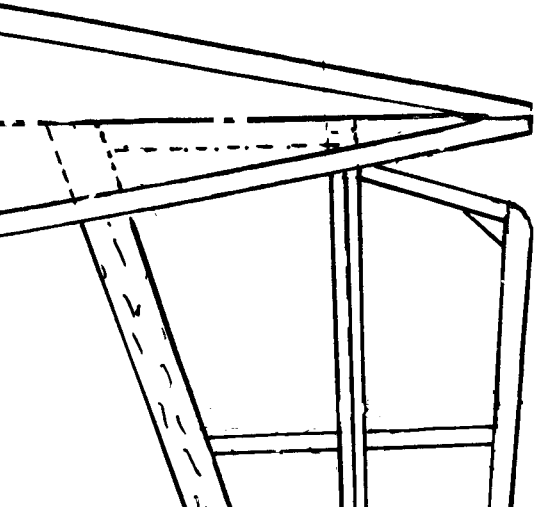
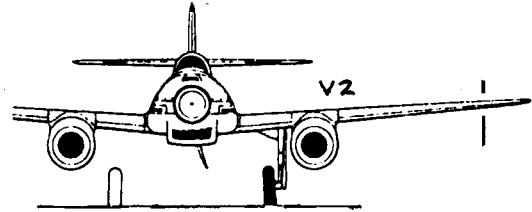

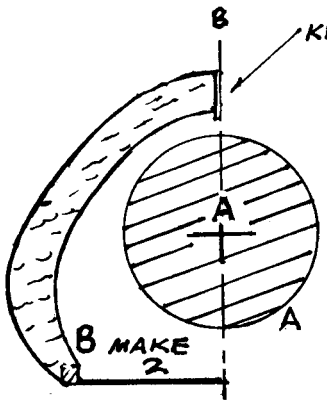

KEEL COLOR-RLM LIGHT GRAY 76

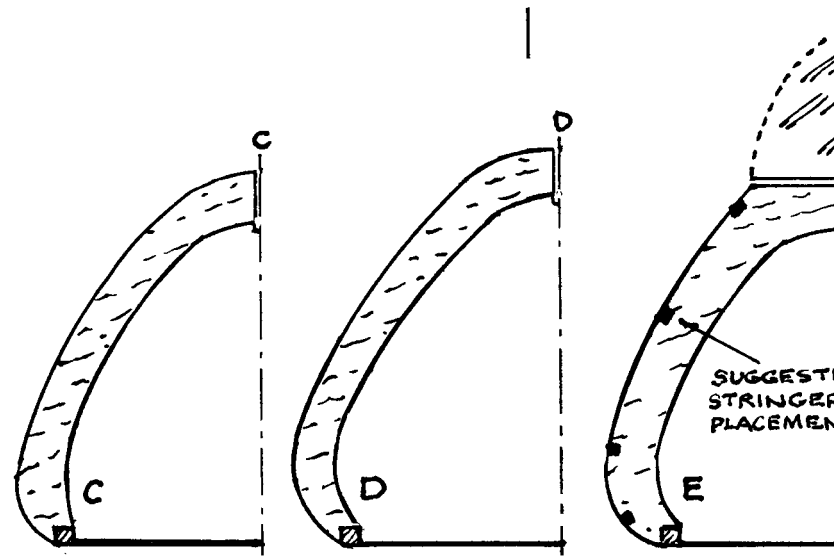
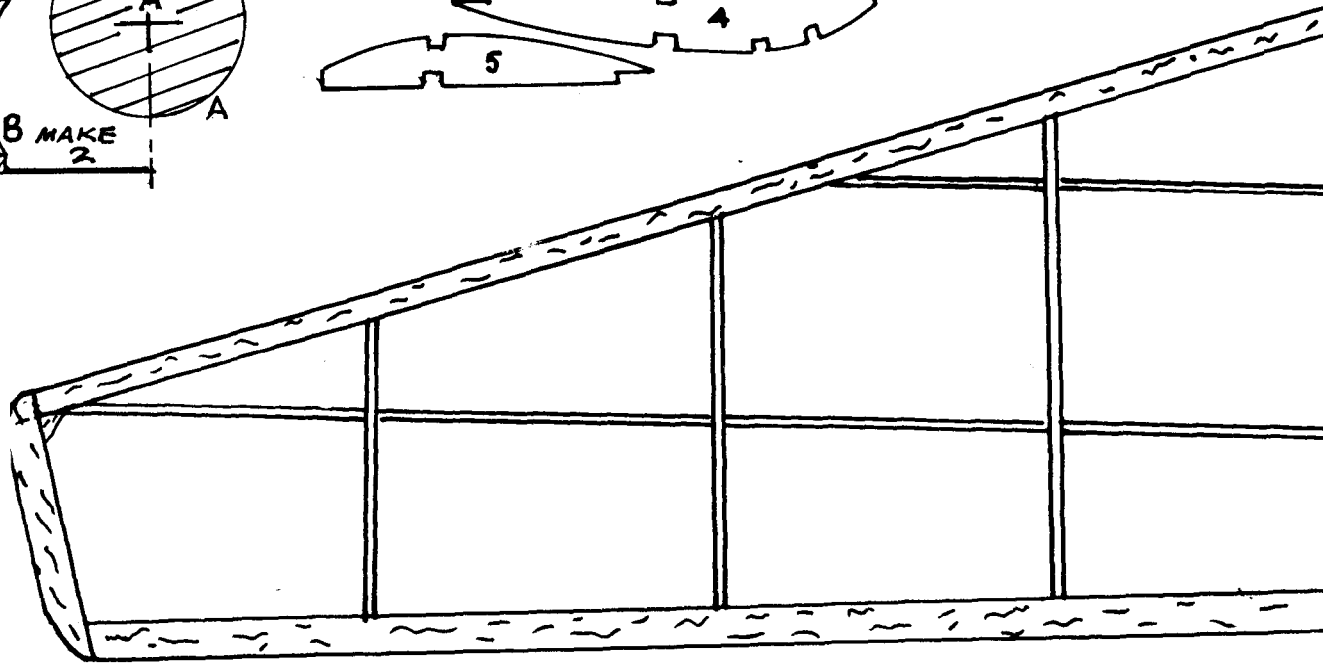
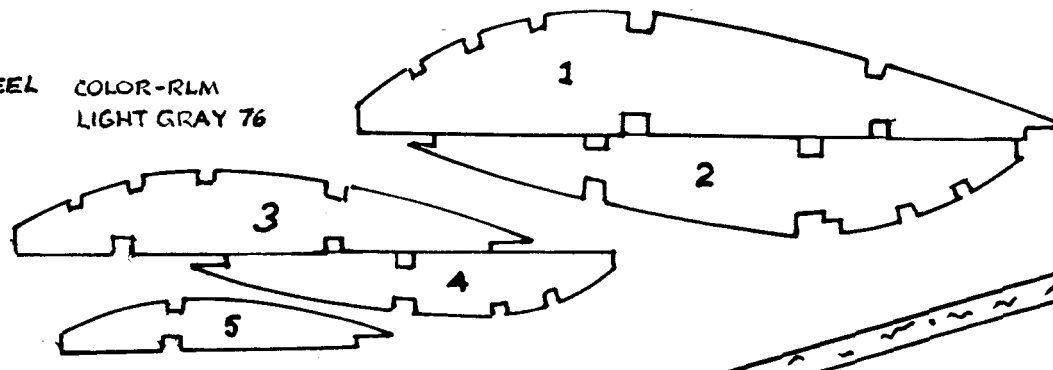

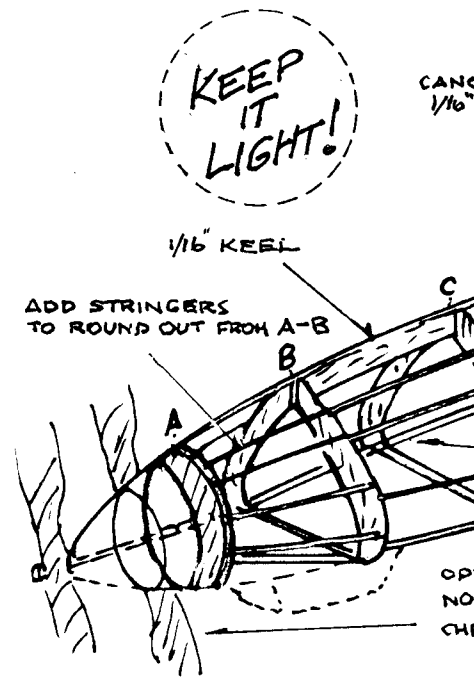
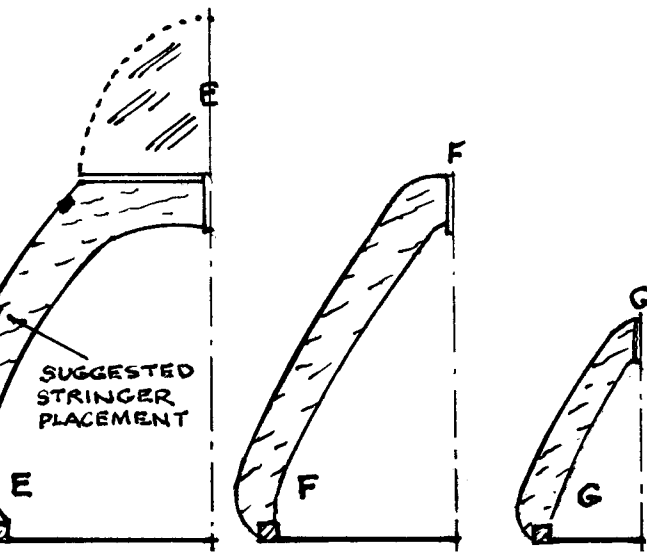
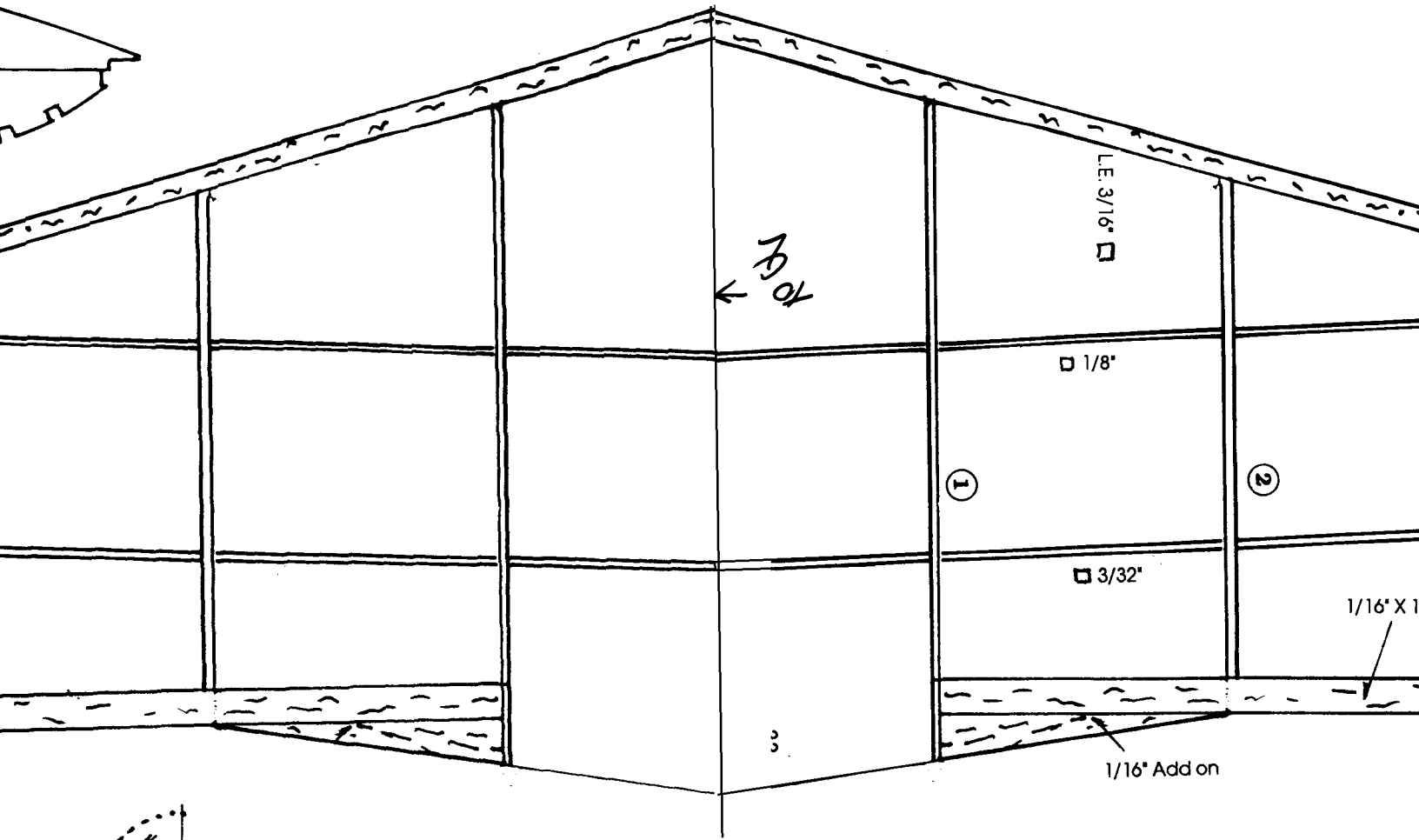

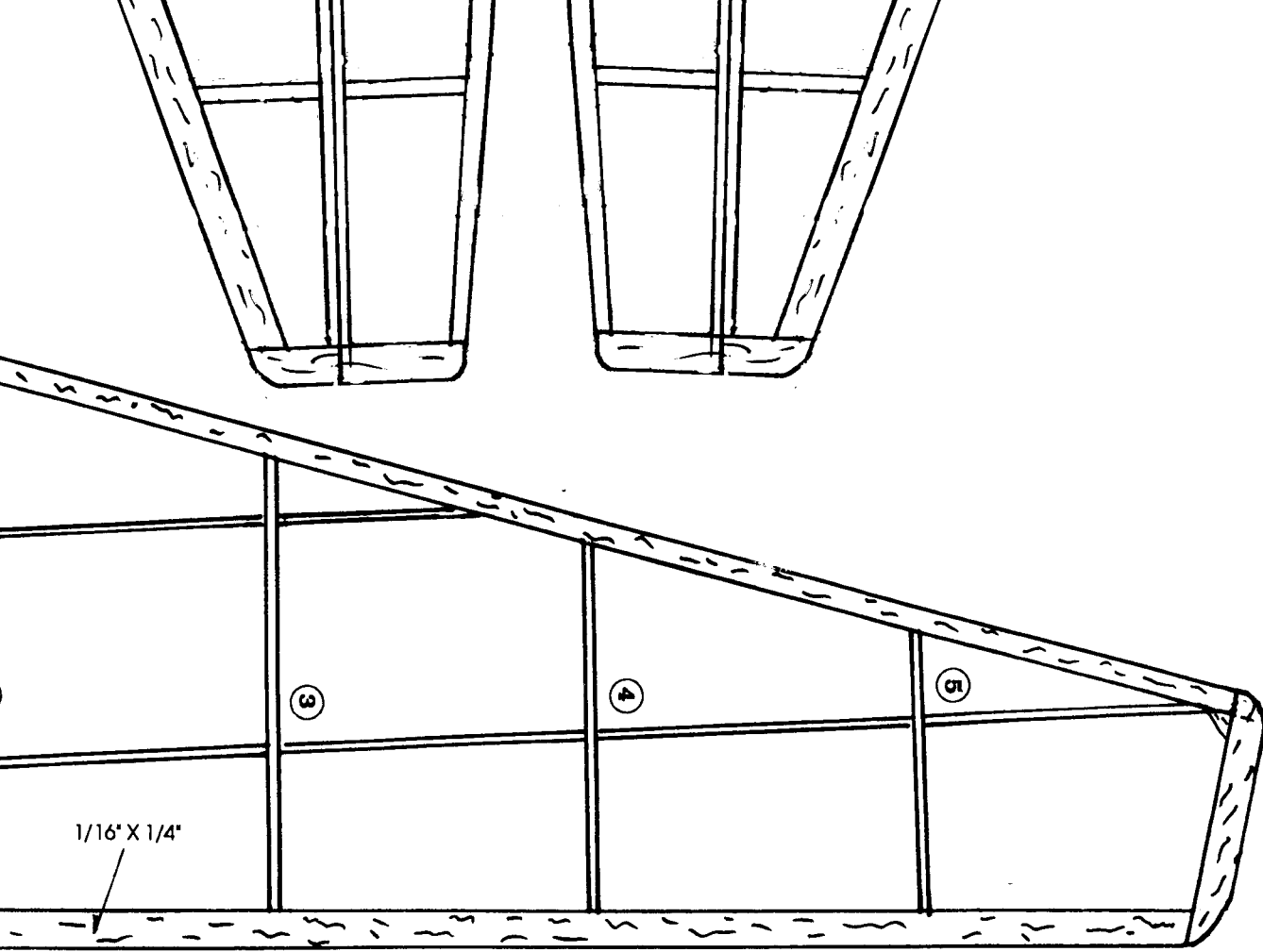

WING TIP DIHEDRAL 1/2"

ROUGH 'HOW TO' SKETCH - NOT TO SCALE.

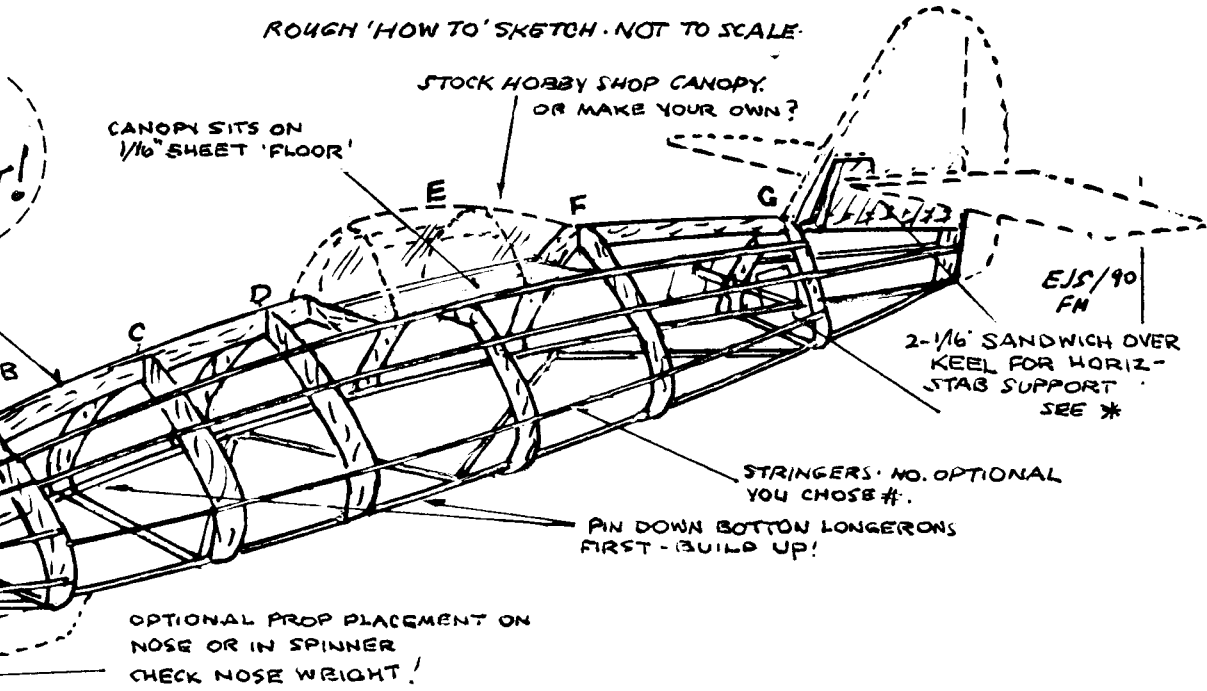

STOCK HOBBY SHOP CANOPY.  
OR MAKE YOUR OWN?

CANOPY SITS ON  
1/16" SHEET 'FLOOR'

EJS/90  
FN

2-1/16" SANDWICH OVER  
KEEL FOR HORIZ-  
STAB SUPPORT  
SEE \*

STRINGERS - NO. OPTIONAL  
YOU CHOSE #.

PIN DOWN BOTTON LONGERONS  
FIRST - BUILD UP!

OPTIONAL PROP PLACEMENT ON  
NOSE OR IN SPINNER  
CHECK NOSE WRIGHT!