

L.E. $3/16 \times 1/4$ " TAPER TO $1/8$ " AT TIP

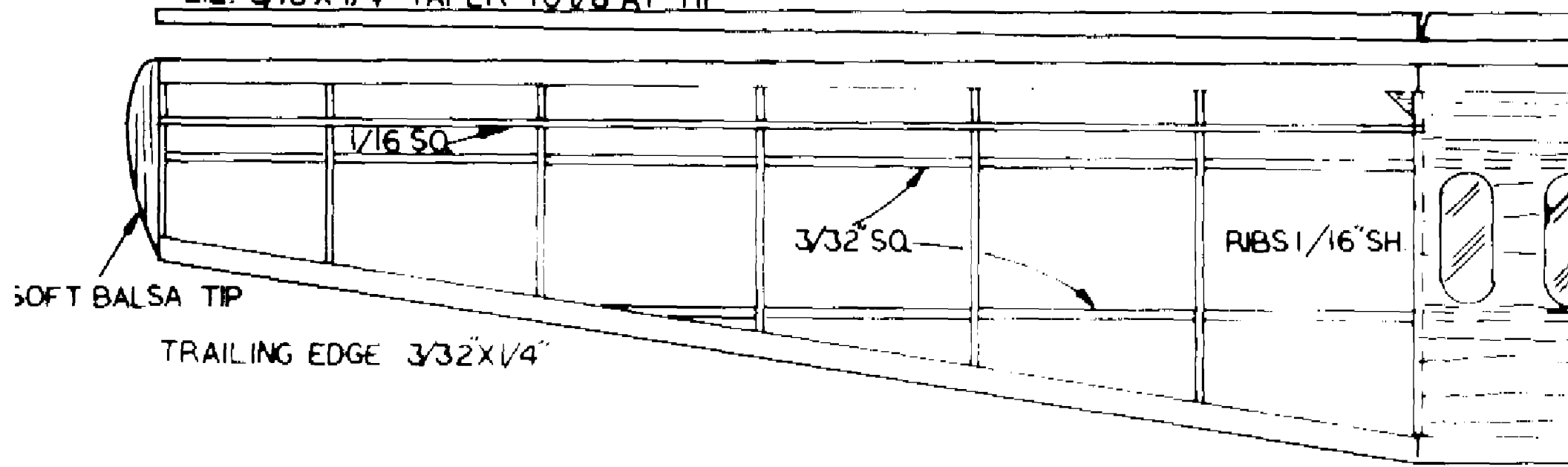

TOP VIEW

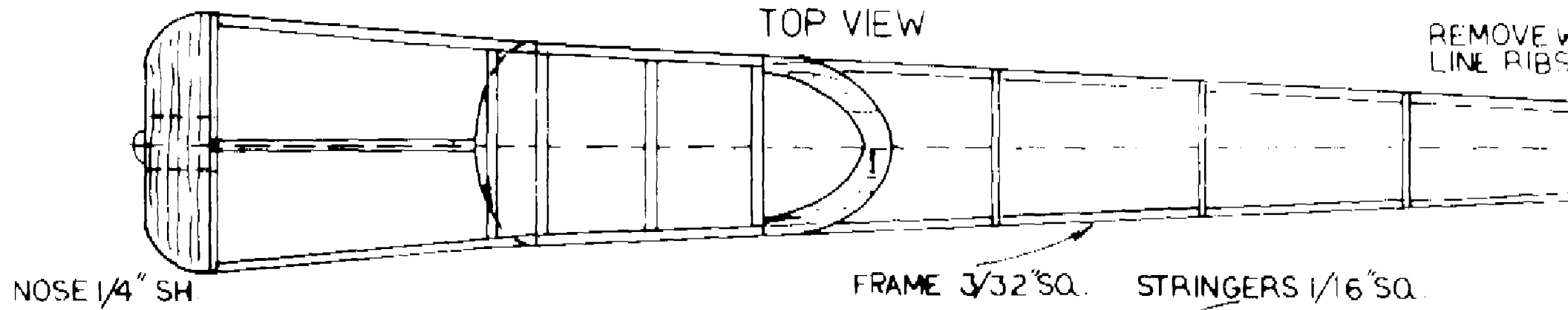

A B C D E F

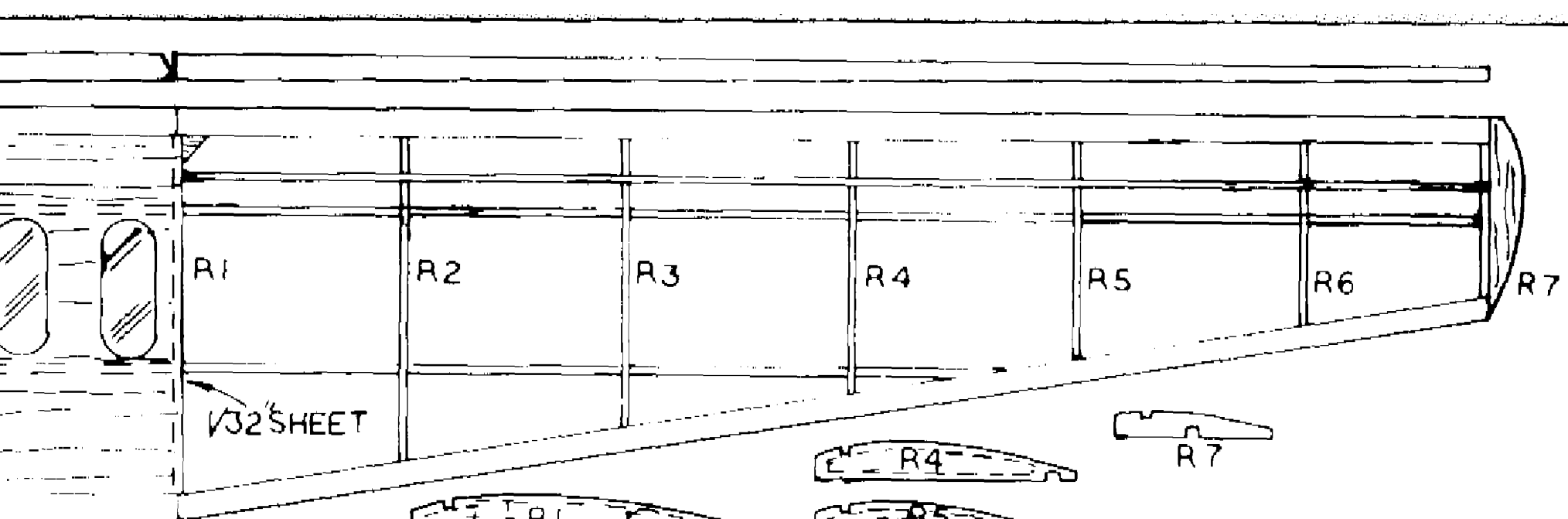

REMOVE WOOD ON DOTTED LINE RIBS R1 THRU R5

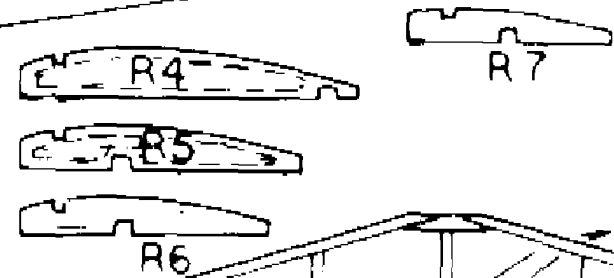
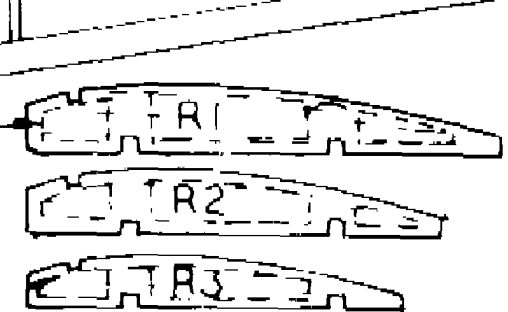

OUTLINE $\frac{1}{32}$ " X $\frac{1}{16}$ " THREE LAMINATIONS

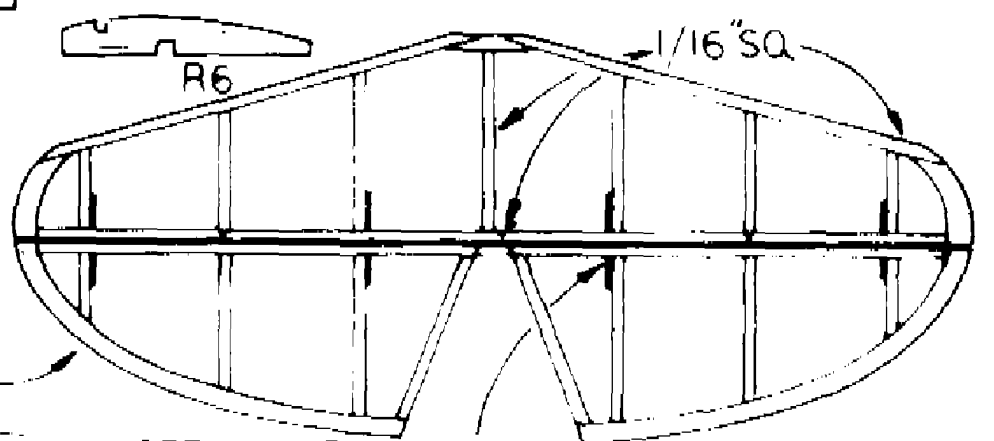

NOSE 1/4" SH

FRAME 3/32 SQ.

STRINGERS 1/16 SQ.

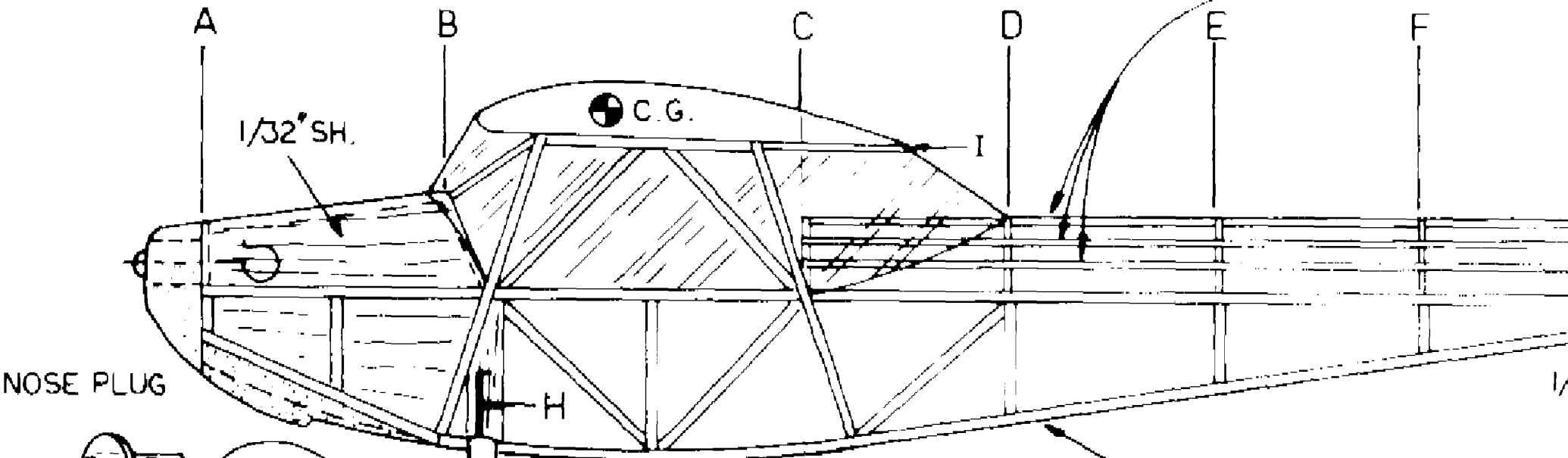

NOSE PLUG

1/32" SH.

C.G.

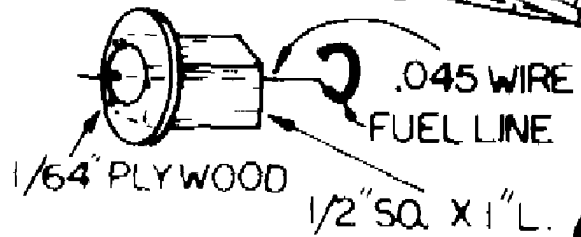

1/64" PLYWOOD

.045 WIRE FUEL LINE

1/2" SQ. X 1" L.

SIDE VIEW

FRAME AND CROSS PIECES 3/32" SQ.

POWER WITH THREE LOOPS 18" LONG. LUBRICATE BEFORE

1 INCH Balsa WHEELS

8" DIA. PECK POLYMERS PROP.

1 1/2" EACH SIDE

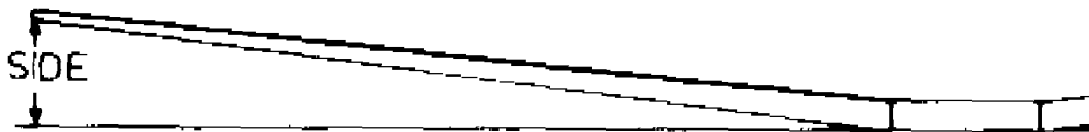

WING NOT TO SCALE

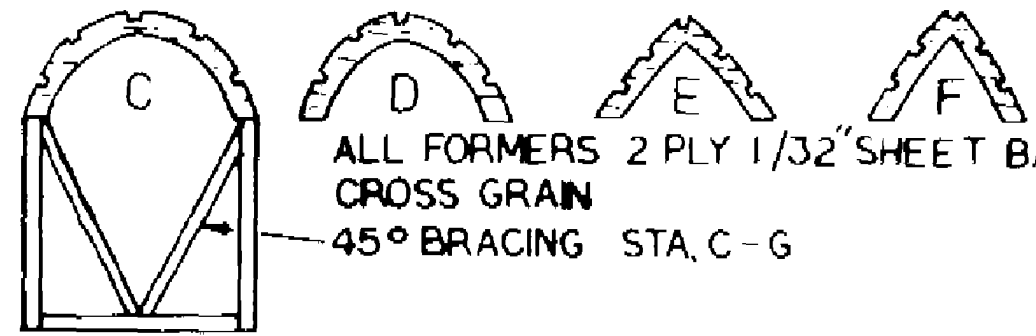
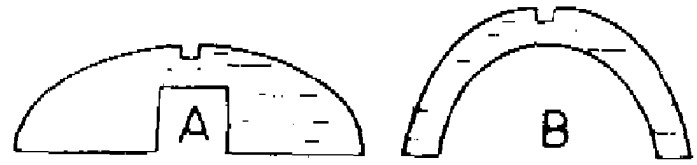

ALL FORMERS 2 PLY 1/32" SHEET BALS. CROSS GRAIN 45° BRACING STA. C-G

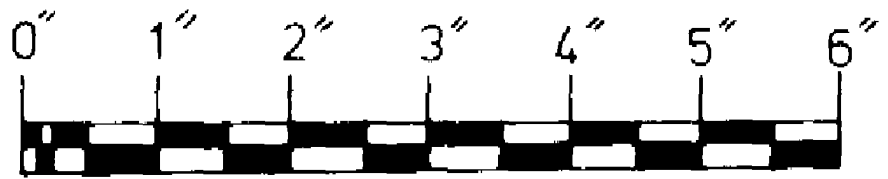

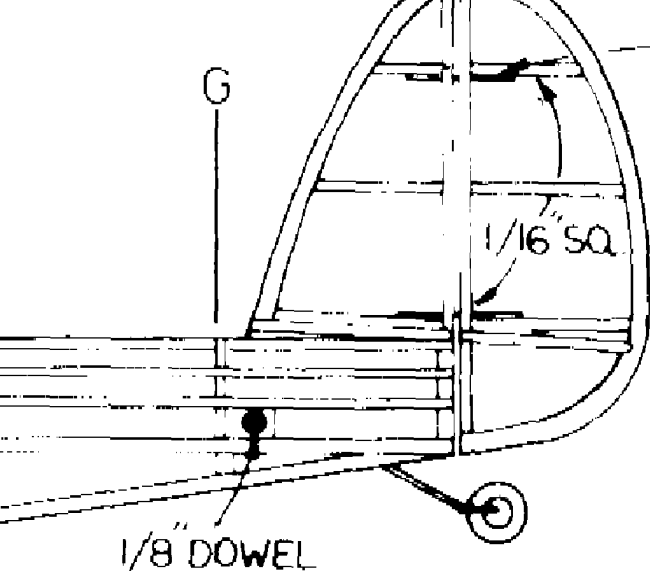

COPPER WIRE HINGES

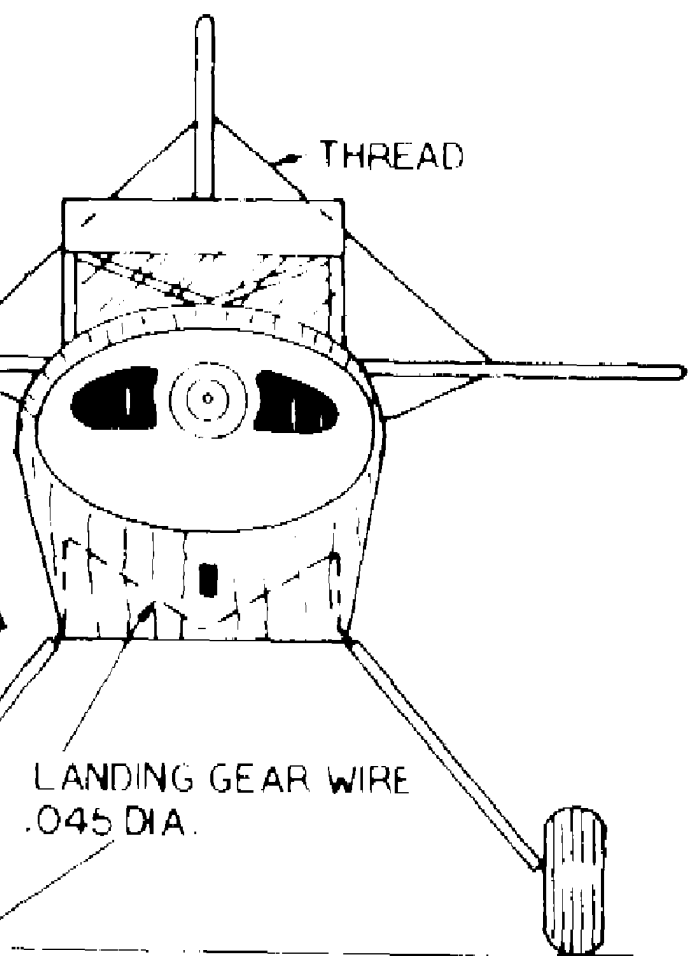
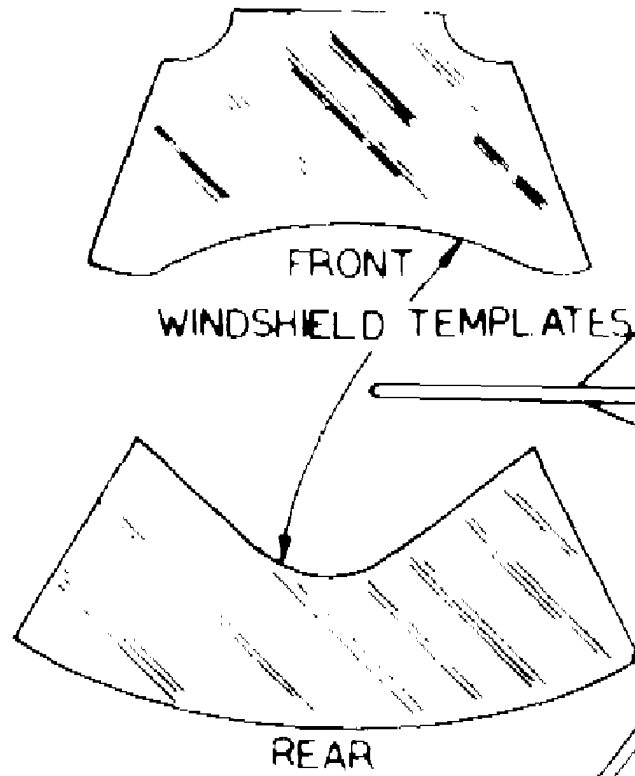

THE LOOPS OF 1/8" SIG RUBBER
TIGHTEN BEFORE WINDING

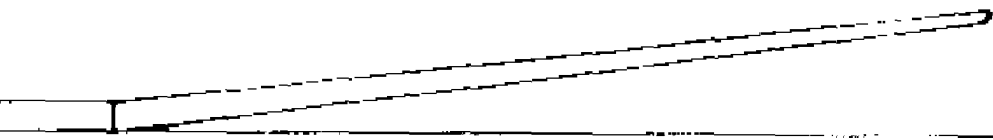

TO SCALE

FRONT VIEW

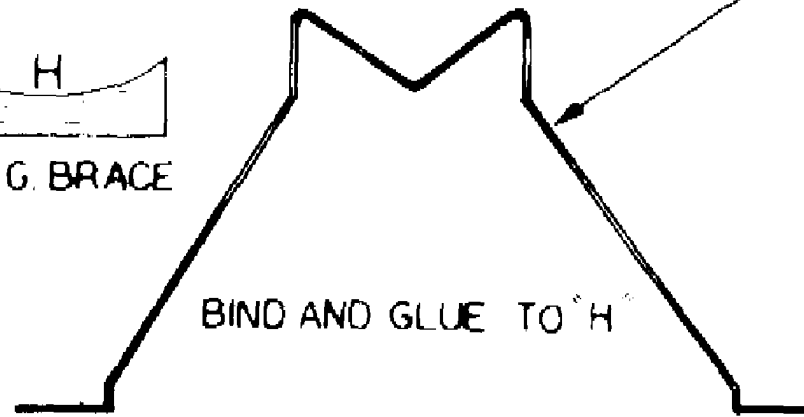

McRae Super Dart
 BY: FLORENT BAECKE
 SCALE: 1"=1'-0" SPAN 27.5"