

TWO FALSE RIBS BETWEEN ALL FULL RIBS

3/32"

3/32" SHEET Balsa

3/32" SQ. WING TIPS

SCALE AILERON LOCATION, TOP AND BOTTOM WINGS

5/8" DIHEDRAL (EACH TIP)
TOP AND BOTTOM WINGS.

1/16" RIB

WING

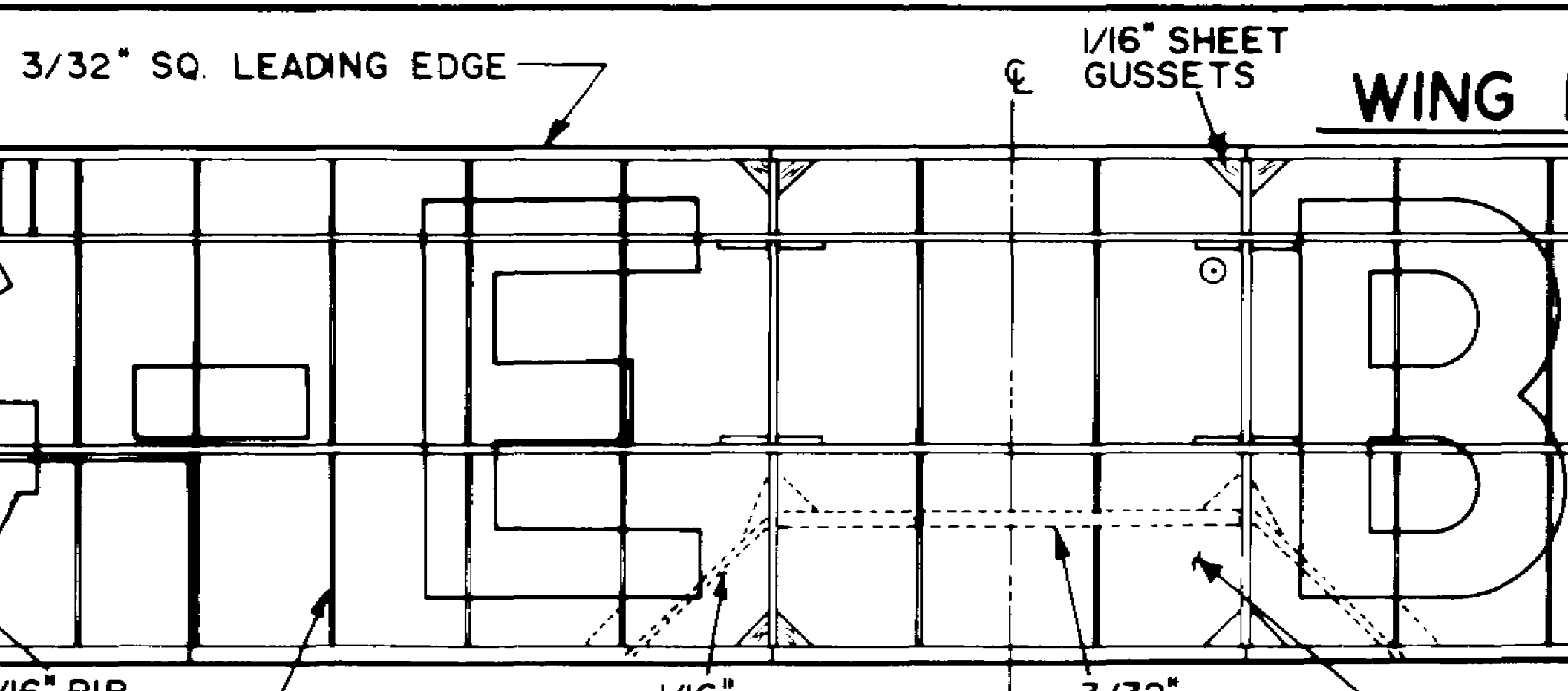

ING PLAN

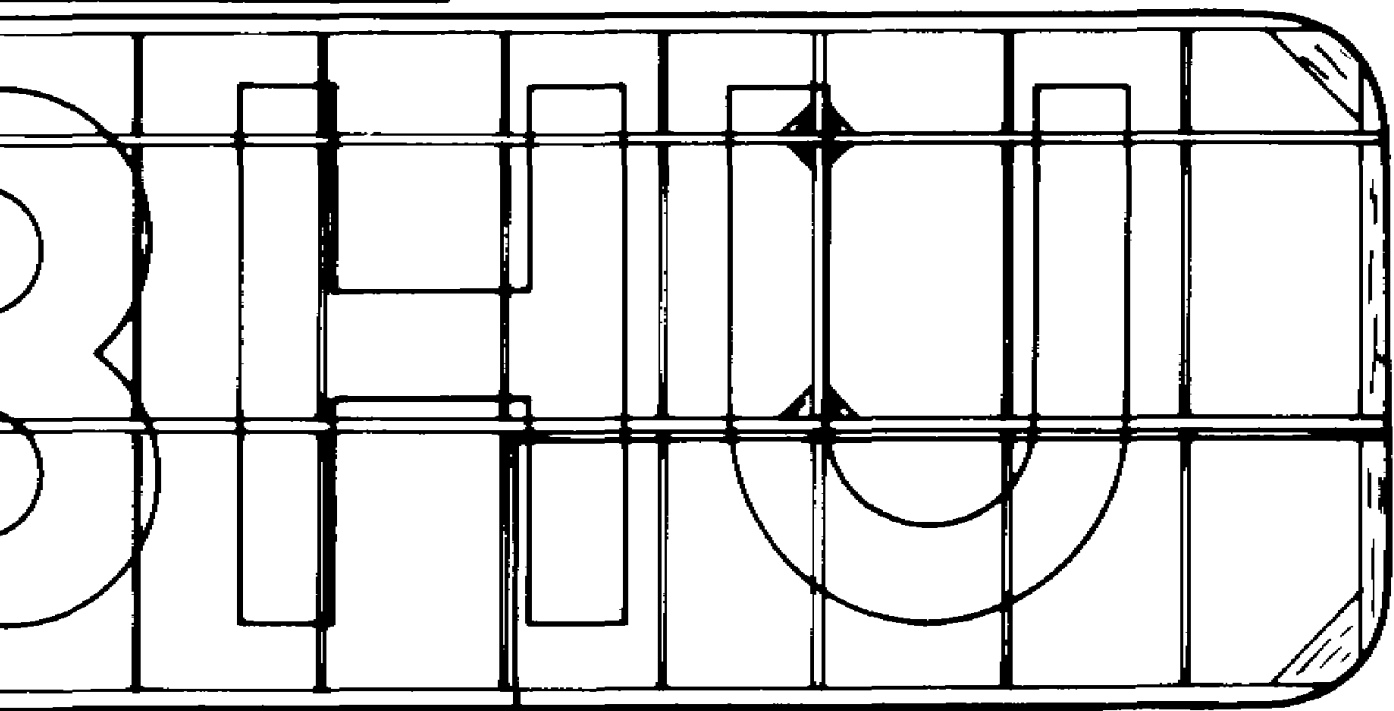

5/8" DIHEDRAL (EACH TIP)
TOP AND BOTTOM WINGS.



1/16" SQ.
1/16" SHEET

1/16" x 1/8" T. E.

1/16" SQ. SPARS

1/32"

5# MONOFILAMENT RIGGING WIRERS & CONTROL CABLES.

32 RIBS - 1/32"
8 RIBS - 1/16" AT DIH. B

FUSELAGE TOP VIEW

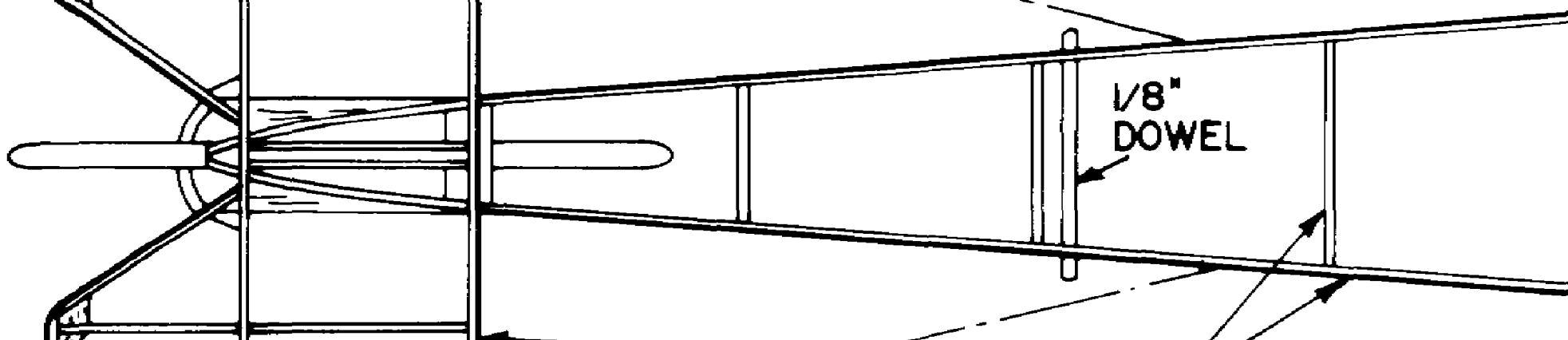

FUSELAGE & TAIL STRUCTURE - 1/16" SQ. Balsa

F-2 THRU F-6 1/16"
F-7 THRU F-11 1/32"

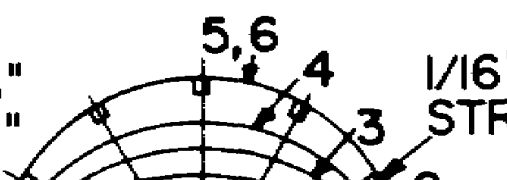

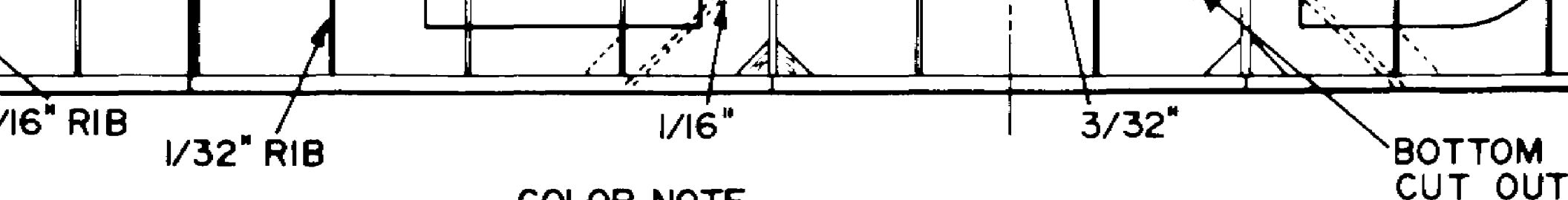

COLOR NOTE:

- PALE BLUE - FUSELAGE & WHEEL DISCS
- CREAM - WINGS, TAIL, STRUTS AND FUSELAGE REGISTRATION
- BLACK - WING REGISTRATION, RACING NUMBER, AND FIN MARKINGS
- METAL - ENGINE AND FUEL TANK

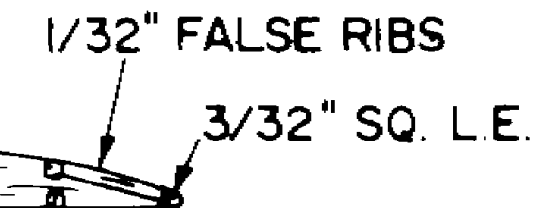

DIH. BREAKS & STRUTS

TOP VIEW

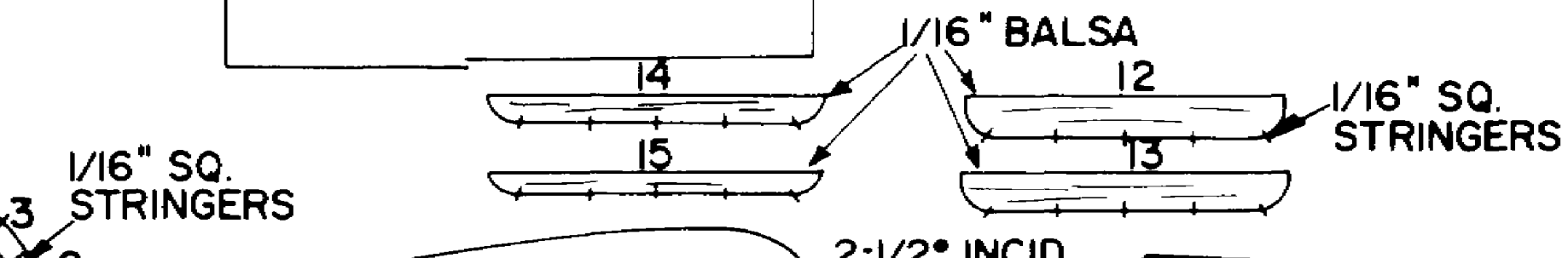
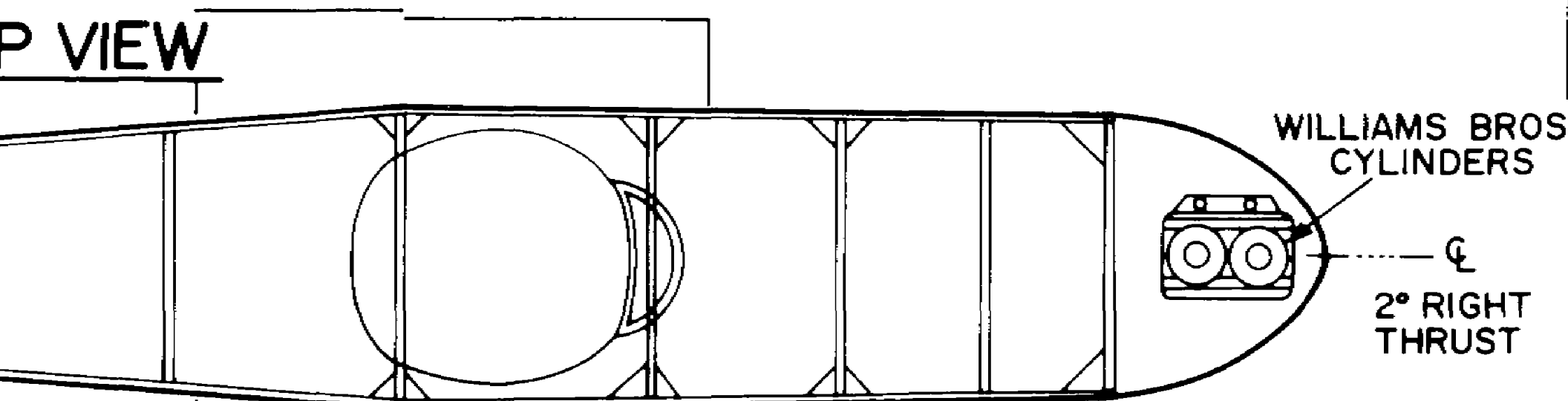

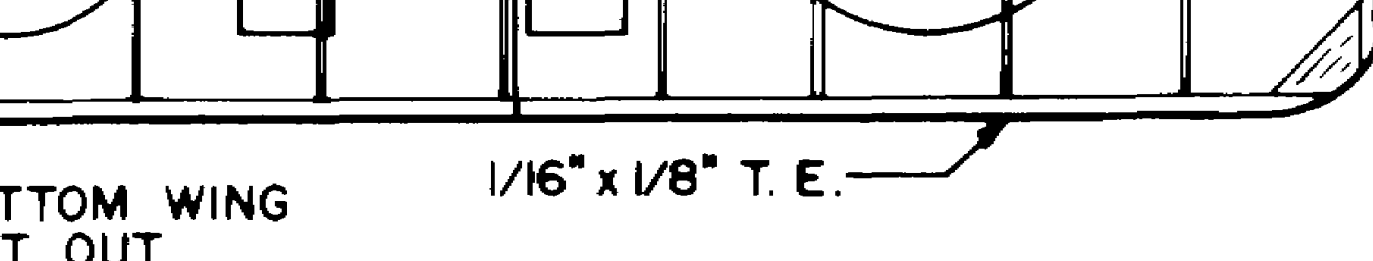

BOTTOM WING
T OUT

1/16" x 1/8" T. E.

FLYING MODELS

GLOSTER GANNET

DESIGNED & DRAWN BY DON SRULL

TRACING BY JOE DEMARCO

ALL RIGHTS RESERVED

BROS.
DERS
Q
IGHT
UST

NOTE: MODEL SHOULD WEIGH 1-1/2 TO 2 OZ. MINUS MOTOR. USE A 9-1/2" PLASTIC PROP CUT TO 8" DIAMETER. TRY MOTORS OF 4 STRANDS 1/8" TO 5/32" RUBBER, ABOUT 24" TO 30" LONG.

GENERAL NOTE: THE GLOSTER GANNET - 1923 BRITISH ULTRA LITE - MODEL IS 1/10 SCALE WING SPAN 21.6" AREA 148 SQ. IN.

VACUUM FORMED,
OR Balsa, FUEL
TANK.

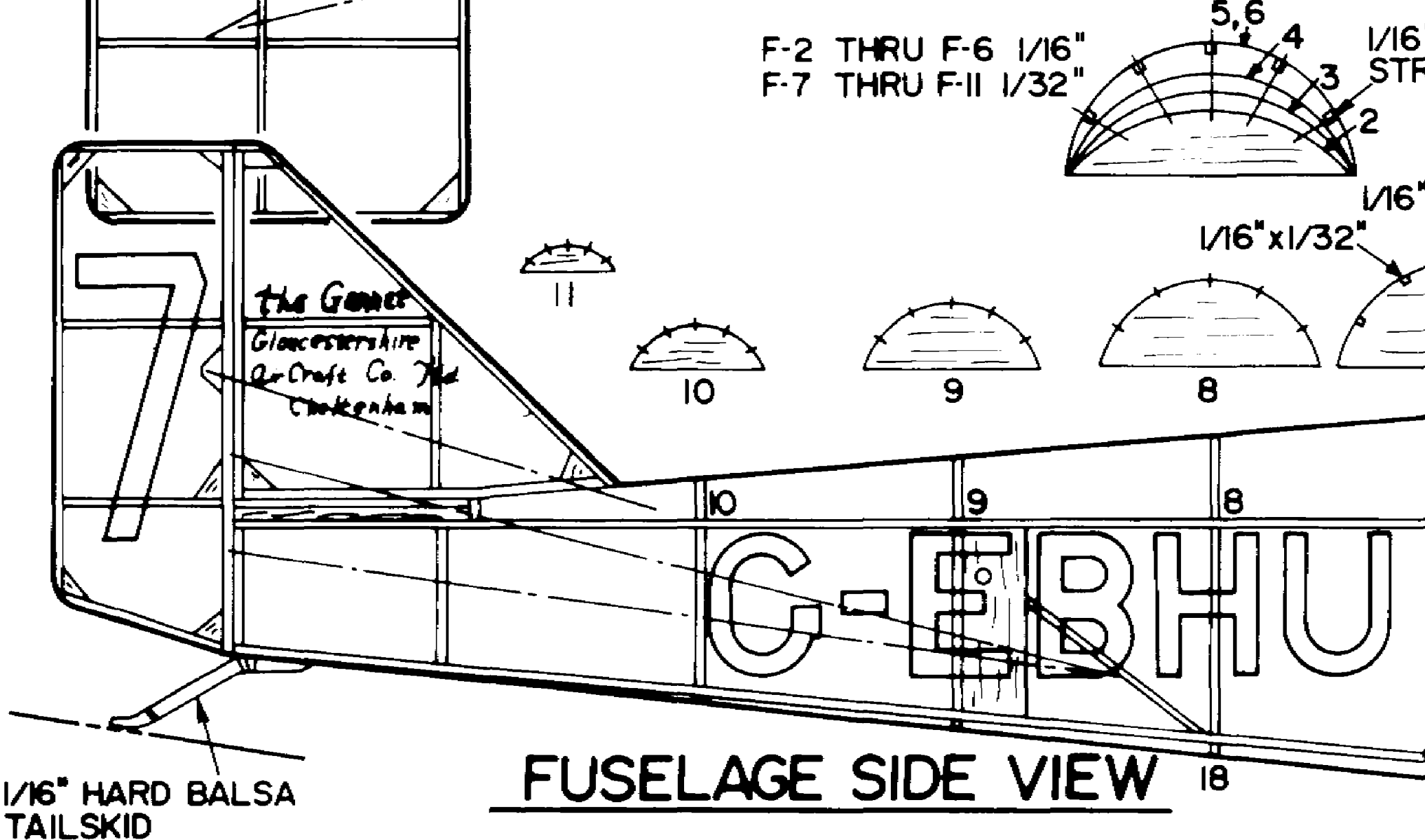

FUSELAGE SIDE VIEW

REFERENCES

- "FLIGHT" MAGAZINE - OCT. 4 & OCT. 23, 1923
- "GLOSTER AIRCRAFT SINCE 1917" - BY D. N. JAMES
- PUTNUM & CO. LTD.

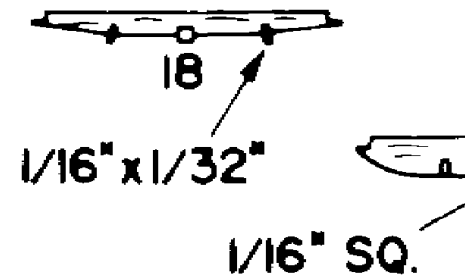

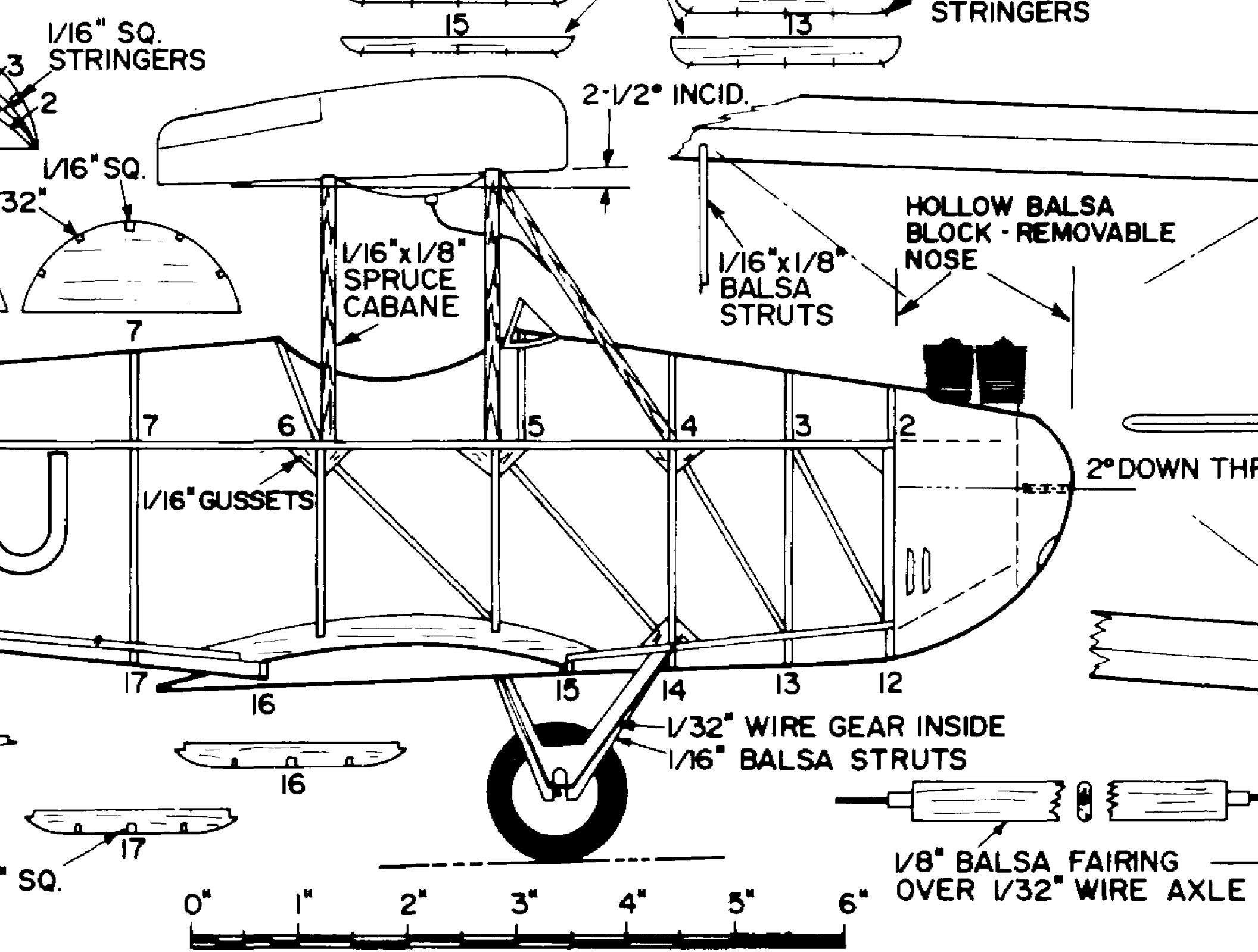

VACUUM FORMED,
OR Balsa, FUEL
TANK.

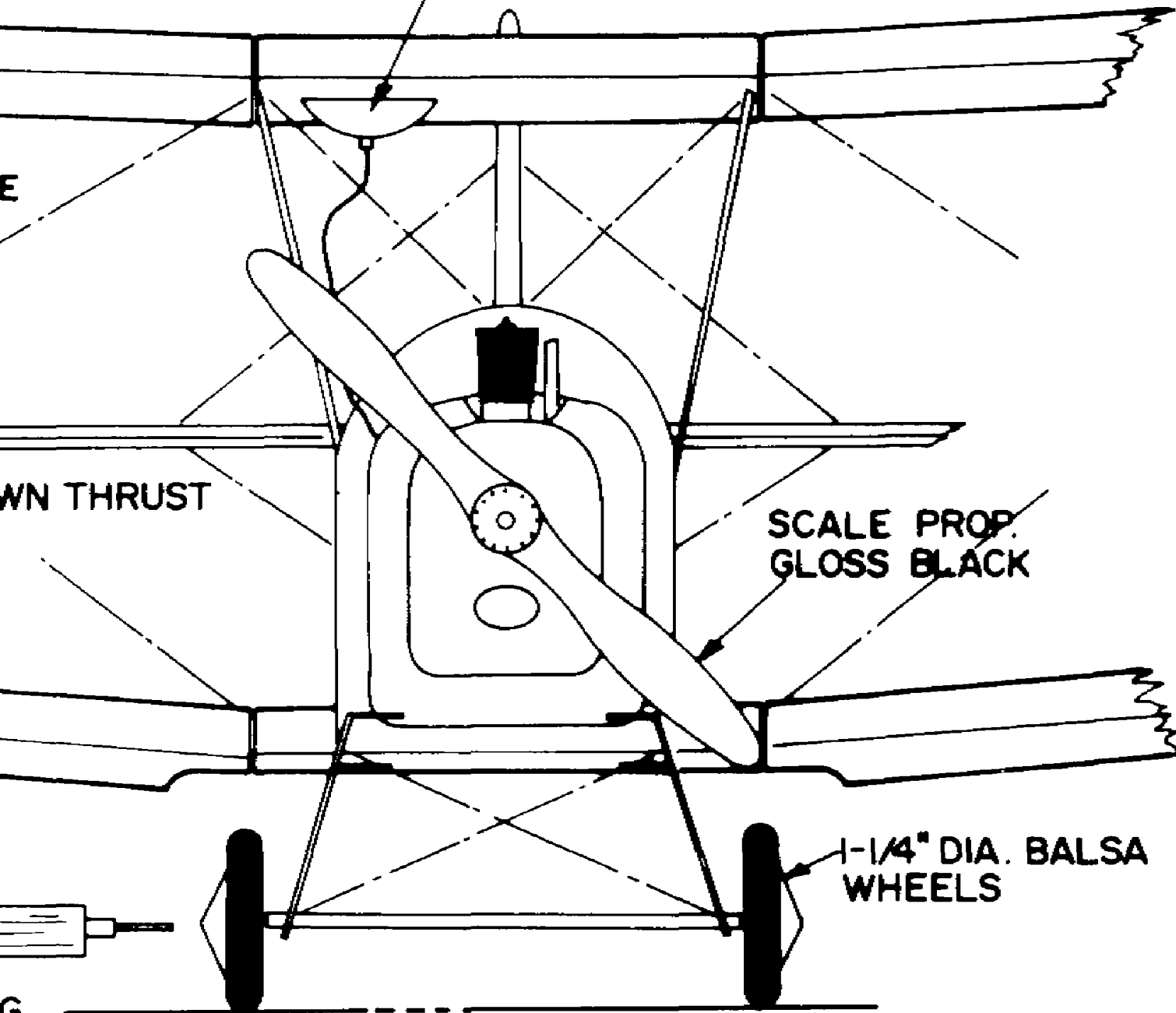

DOWN THRUST

SCALE PROP.
GLOSS BLACK

1-1/4" DIA. Balsa
WHEELS

AXLE

FRONT VIEW