

AUSTRIAN INSIGNIA IS RED & WHITE ON WING TIPS AND TAIL AS SHOWN. BOTTOM SURFACE OF BOTH WINGS ARE STRIPED IN THIS SAME MANNER

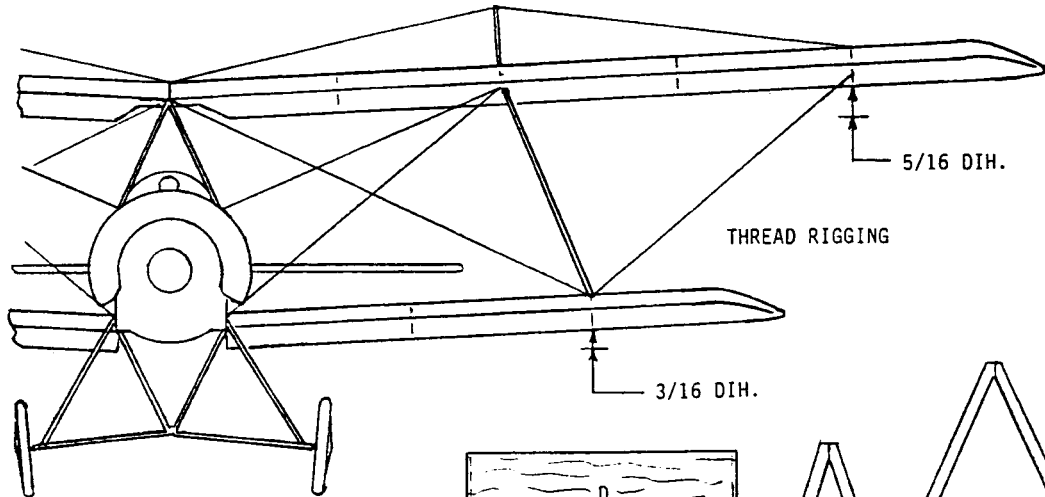

FRONT VIEW

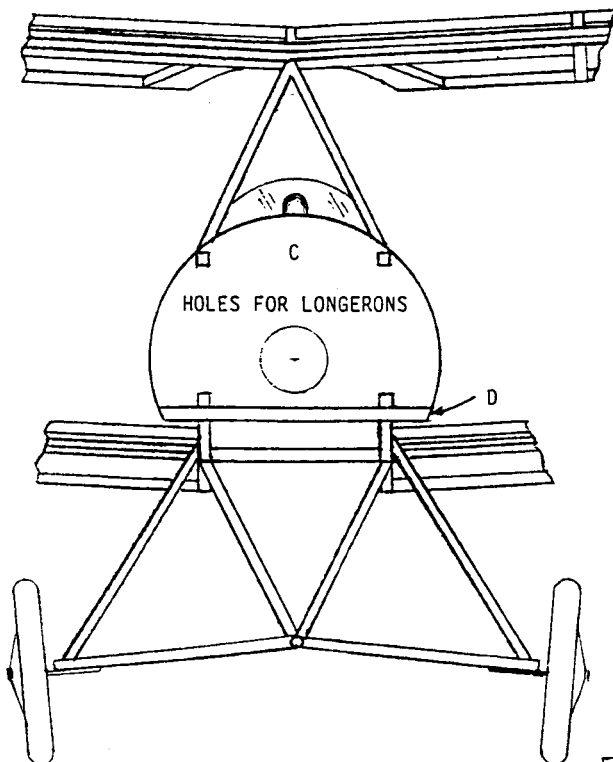
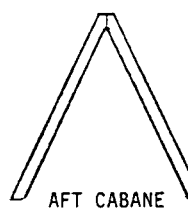
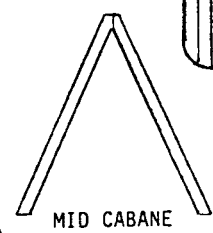
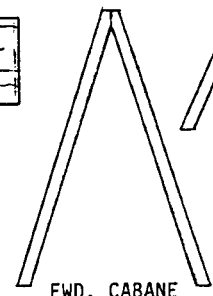

FULL SIZE FRONT L.G. STRUTS  
MAKE OVER DI AN

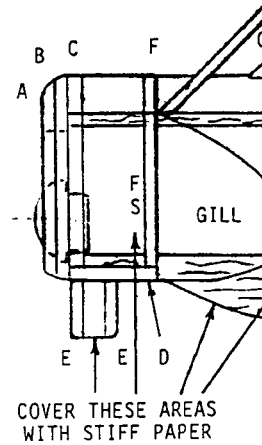
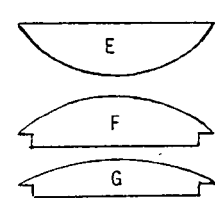
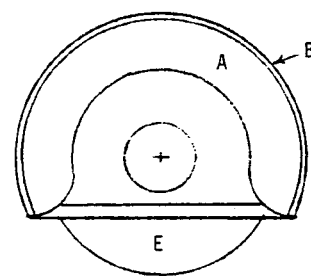

COVER THESE AREAS WITH STIFF PAPER

1 INCH WHEEL  
USE PIN FOR AXLE



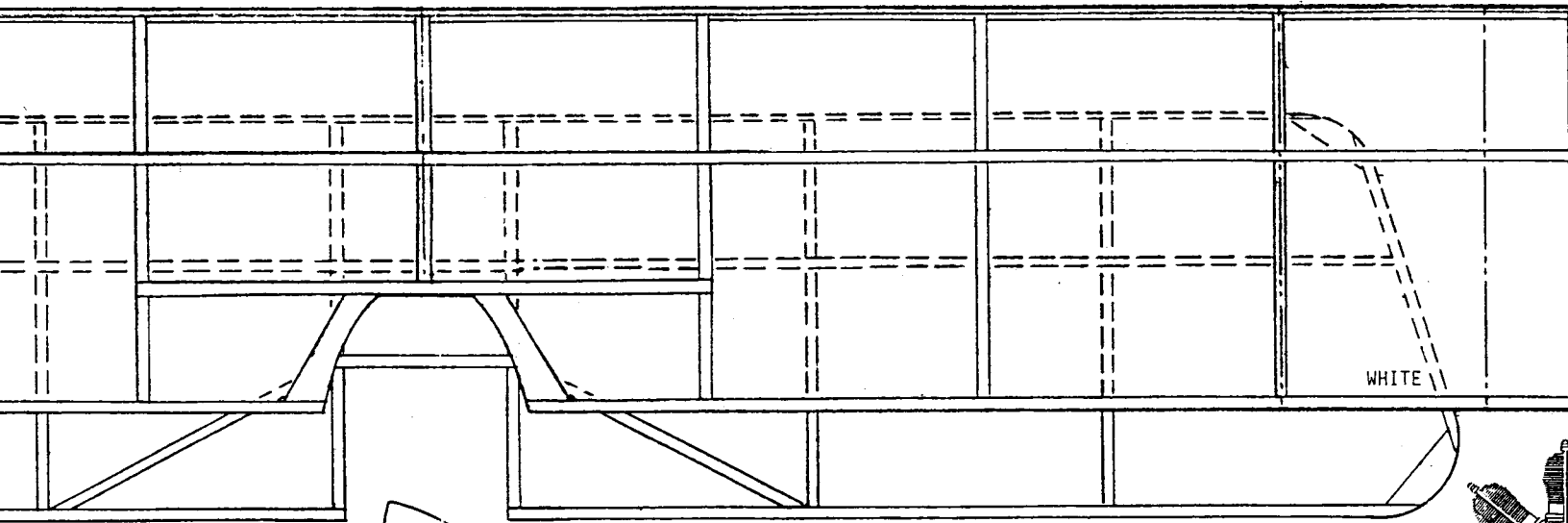

WHITE

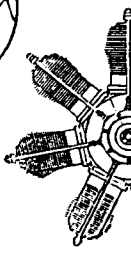

MOTOR  
TRIM TO FIT  
ON NOSE  
INSIDE COWL

COLOR SCHEME

ALL STIFF PAPER PARTS GREY,  
REST OF SHIP IS OFF WHITE.  
BAY STRUTS NATURAL, ALL OTHERS GREY.  
AUSTRIAN INSIGNIA IS RED AND WHITE  
STRIPES AS SHOWN. BLACK NUMERALS.

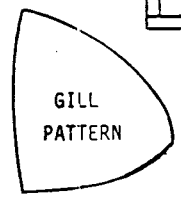

GILL  
PATTERN

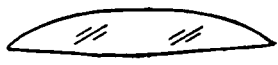

MAKE TWO WINDSHIELDS  
FROM THIS PATTERN

GILL  
OPEN AT BOTTOM

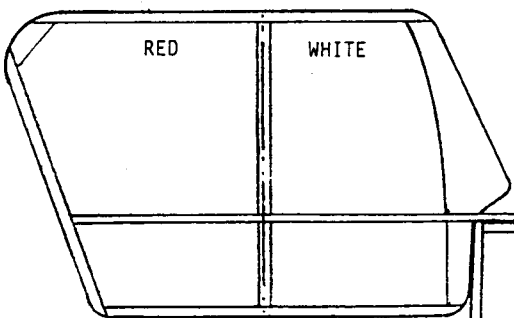
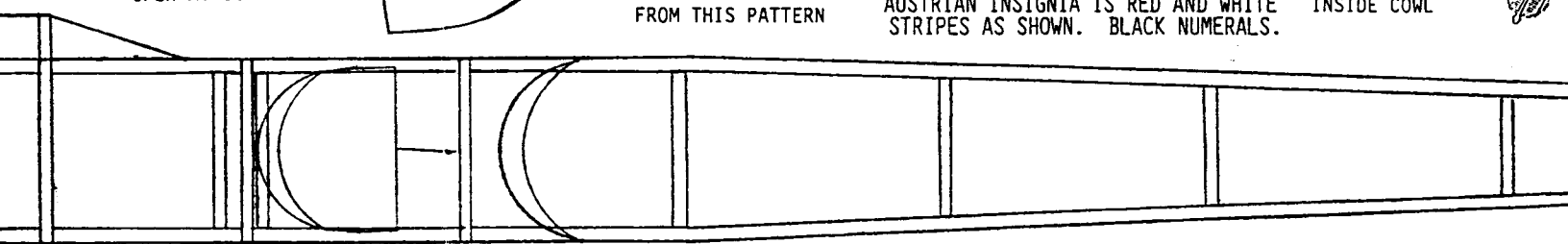

MAKE STABILIZER SPAR FROM BAMBOO

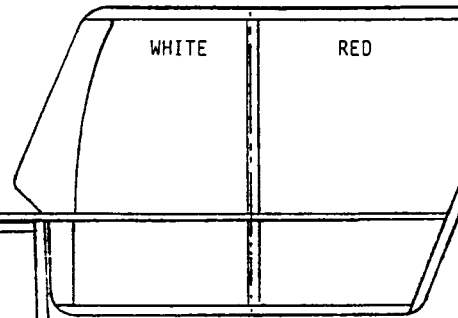

CUT NUMBERS FROM PLAN  
AND STICK TO FUSELAGE SIDES

**03.09**

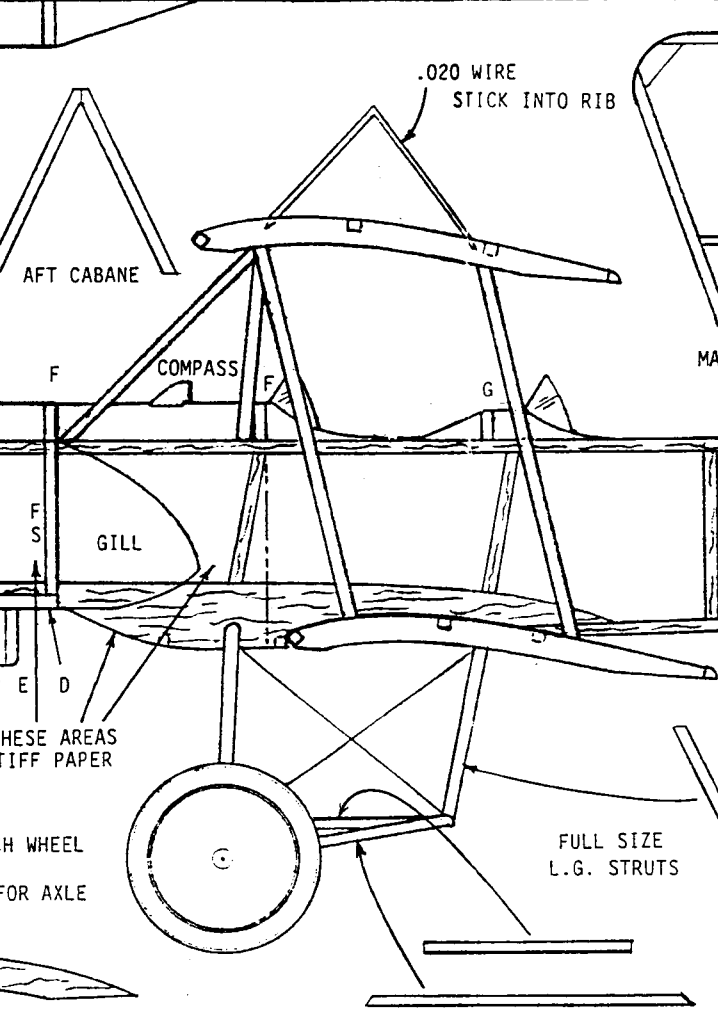

.020 WIRE  
STICK INTO RIB

AFT CABANE

COMPASS

GILL

THESE AREAS  
STIFF PAPER

WHEEL  
FOR AXLE

FULL SIZE  
L.G. STRUTS

**03.09**

HARDWOOD DOWEL  
MOTOR PEG

REAR COCKPIT PATTERN  
MAKE FROM STIFF PAPER  
FRONT COCKPIT PATTERN

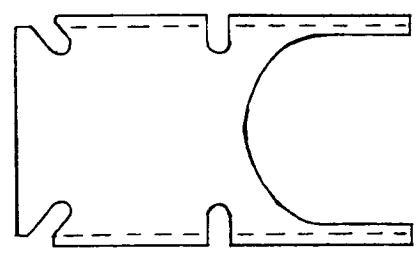
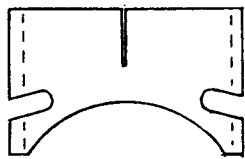

**AIRDEV**  
AUSTRO HU  
WINGSPREAD  
DRAWN BY-  
TEST PILOT

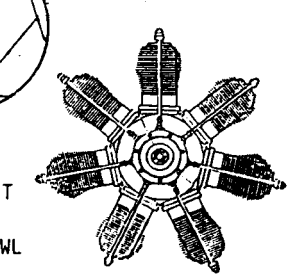
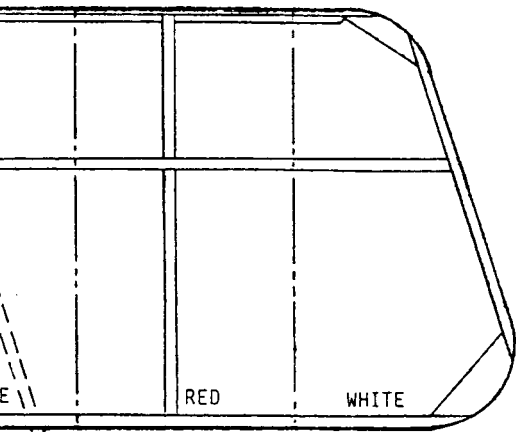

FULL SIZE  
BAY STRUTS

FWD.    AFT

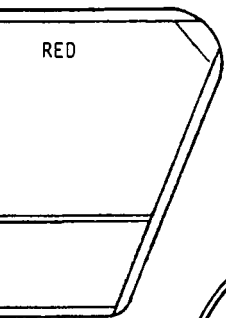
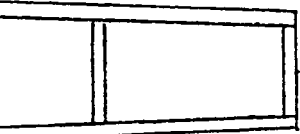
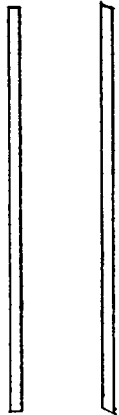

RED

ALL WOOD IS 1/16  
BAMBOO OUTLINE

3.09  
GE SIDES

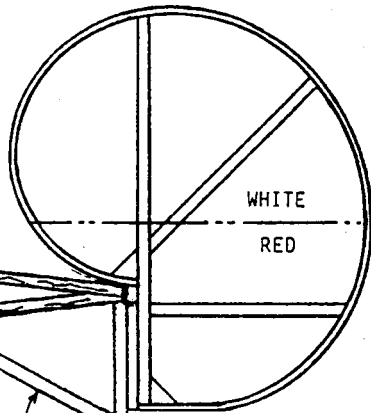

WHITE

RED

TWO STRUTS

MOUNT STABILIZER AT  
SAME ANGLE AS BOTTOM WING

**AIRDEVIL MODEL CO.** ★

AUSTRO HUNGARIAN FOKKER B-1  
WINGSPREAD-16"    PRICE- 10¢  
DRAWN BY- FOKKER  
TEST PILOT O.K.- FELDWEBEL HEFTY