

K1041

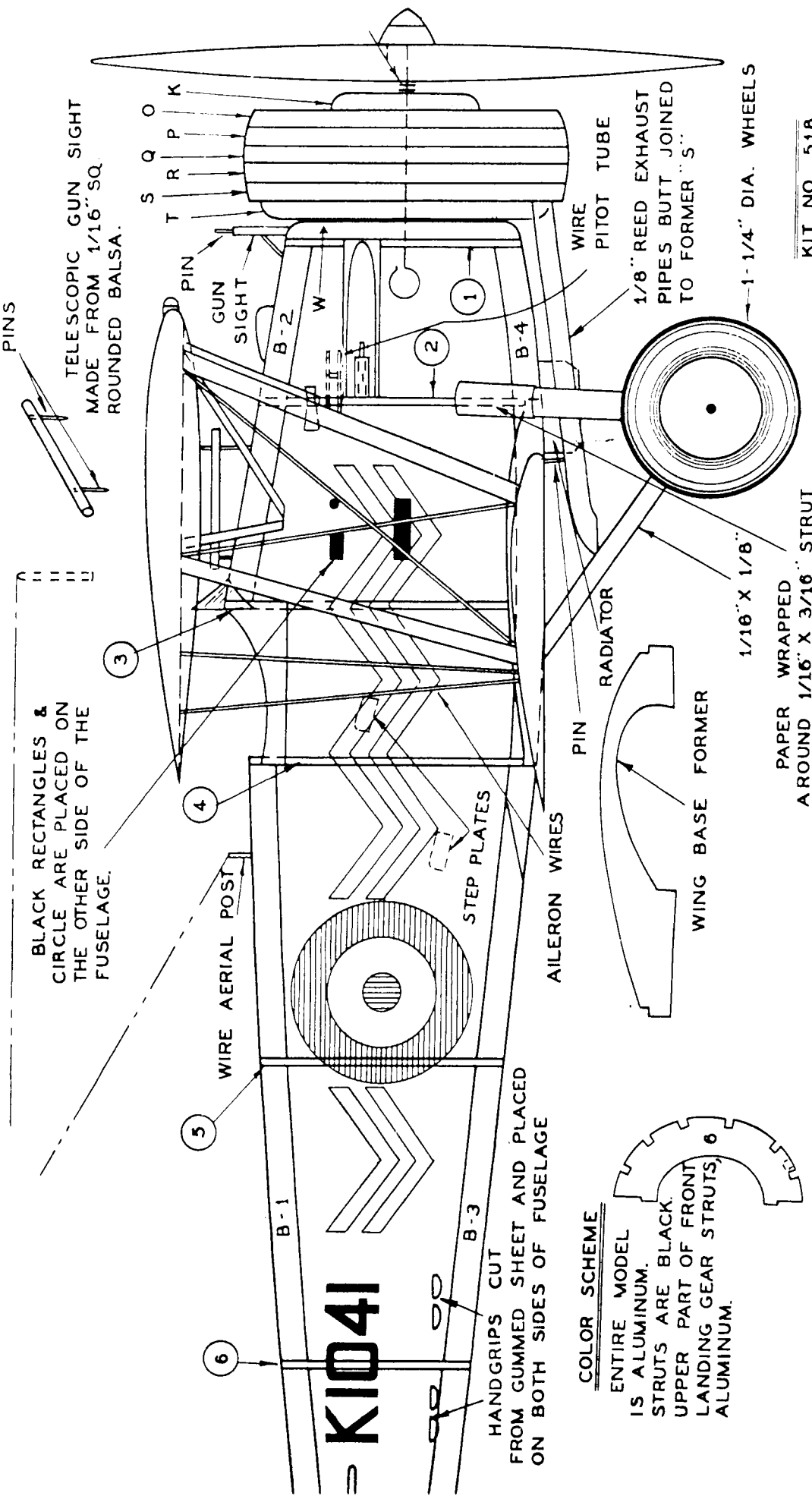

KIT NO. 518

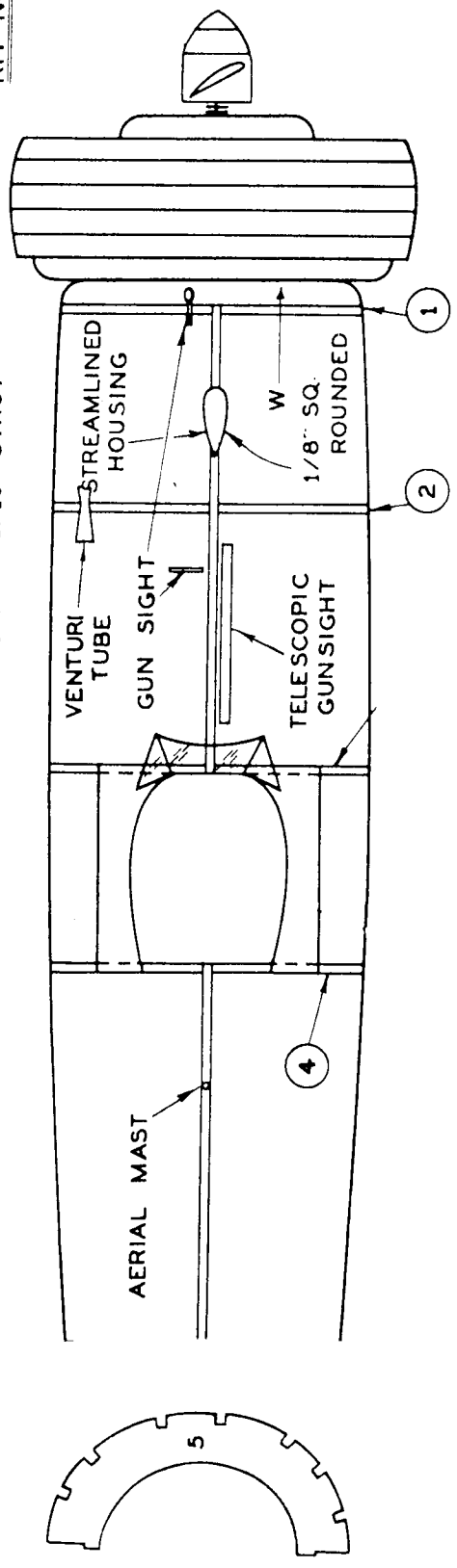

3/32" SQ. LEADING EDGE

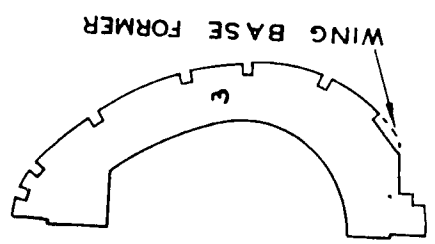
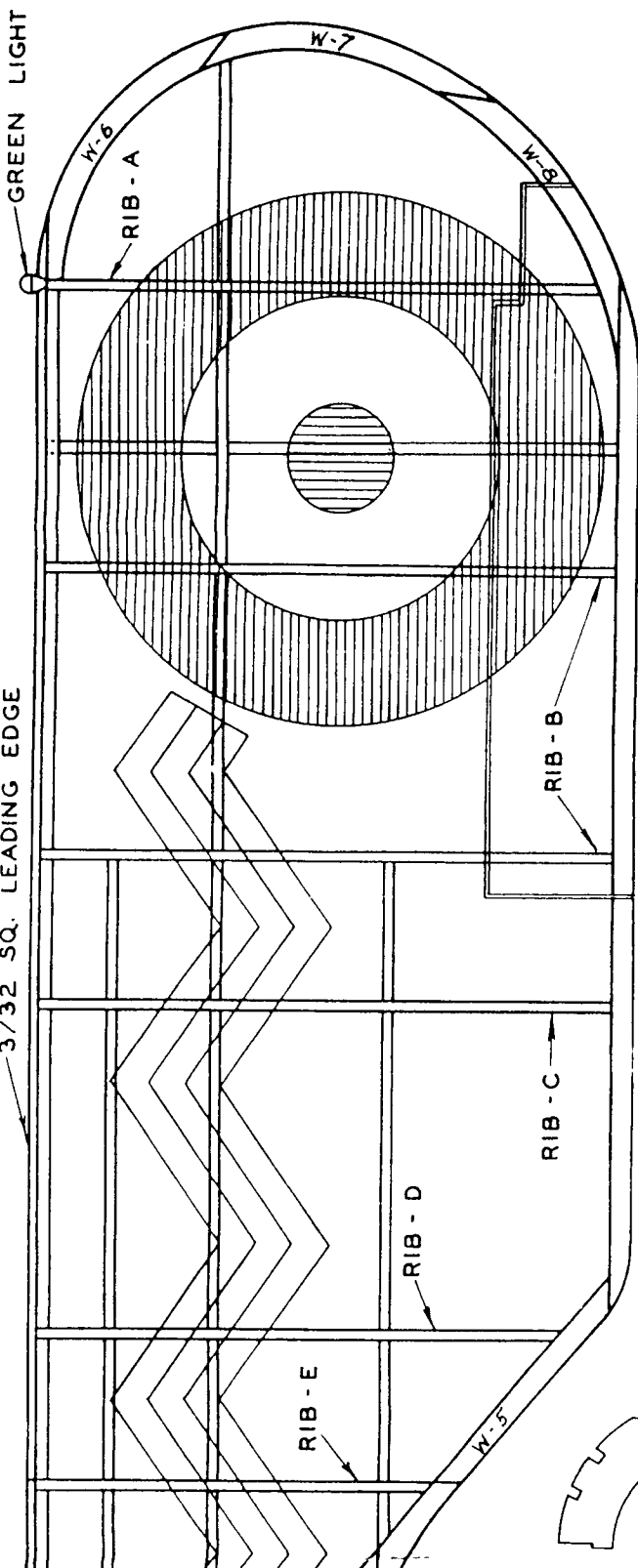

MACHINE GUN TROUGH IS PLACED IN NOTCH OF FORMER 1, AND AGAINST FORMER 2.

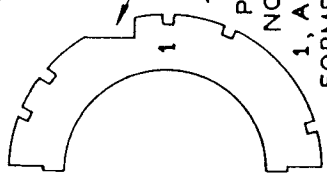

3/32" SQ. LEADING EDGES

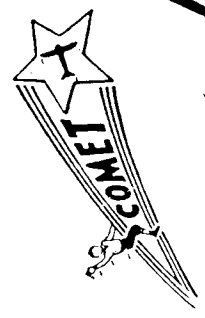
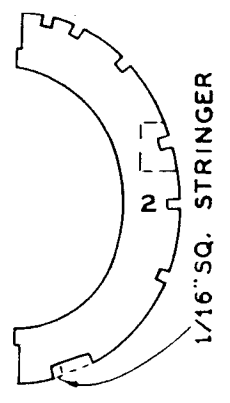
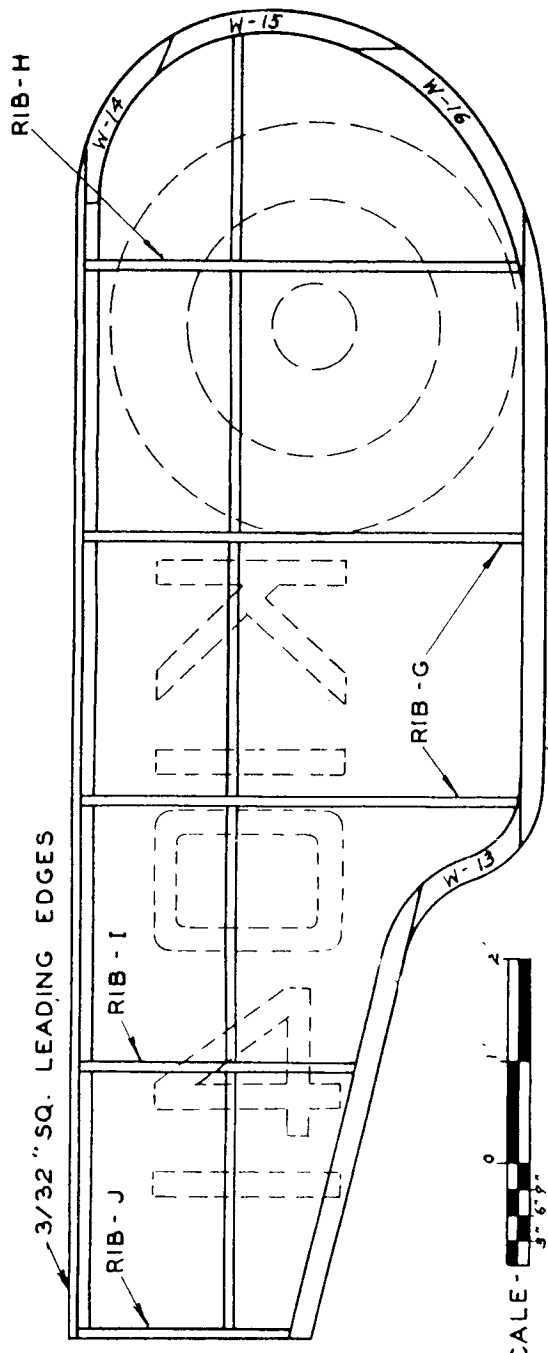

BULLDOG

Bristol

WINGSPAN 18"
OVERALL LENGTH—12-3/4"

© 1936 BY

COMET MODEL AIRPLANE & SUPPLY CO. INC. CHICAGO.

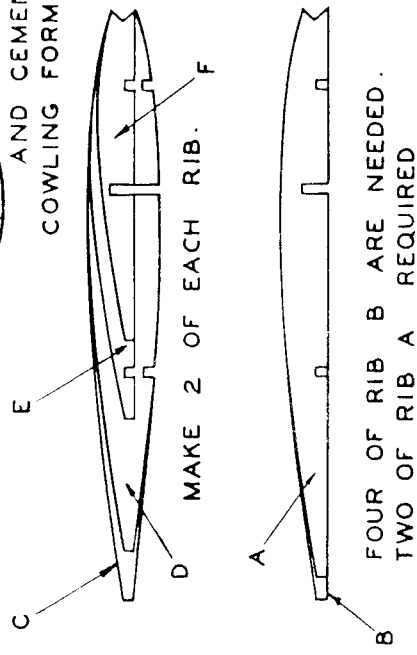
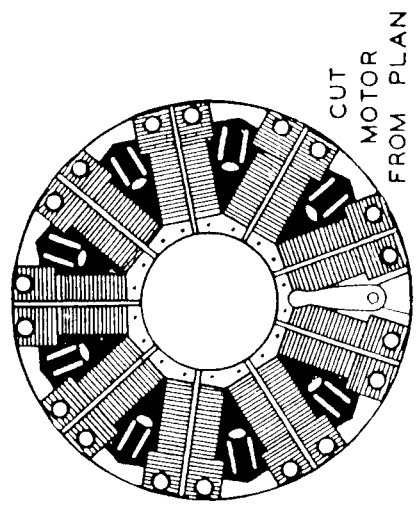
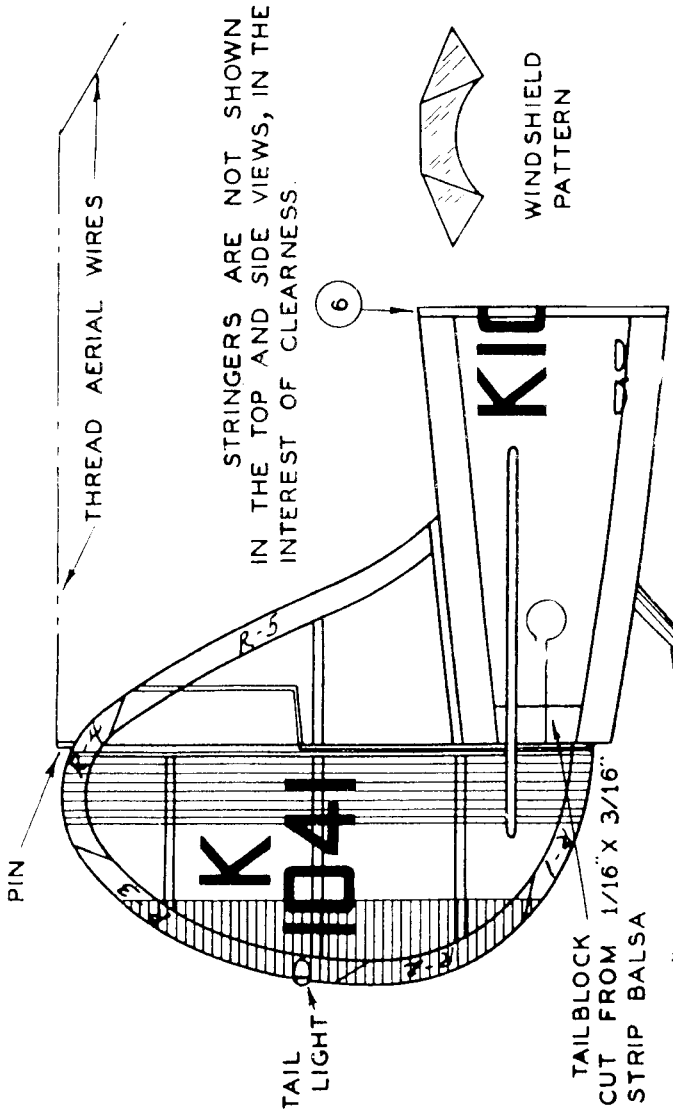

COWLING IS BUILT UP OF 1/8" SHEET Balsa AS SHOWN IN SECTIONAL VIEW.

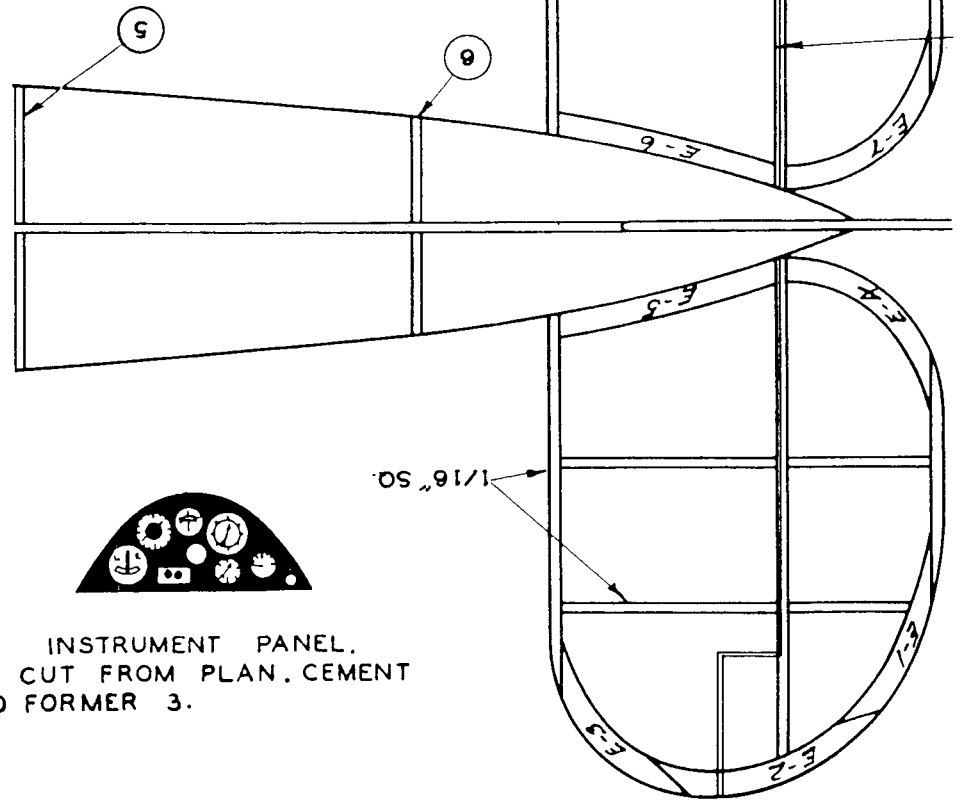
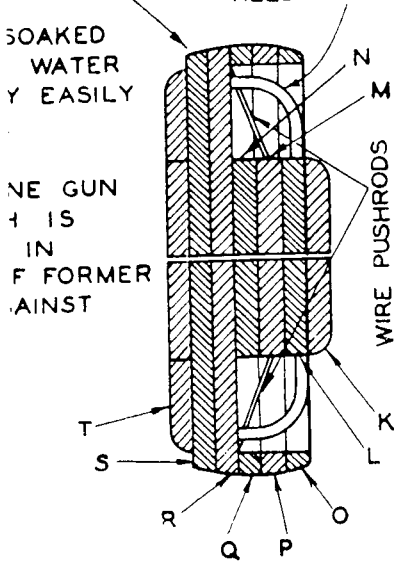

RED LIGHT

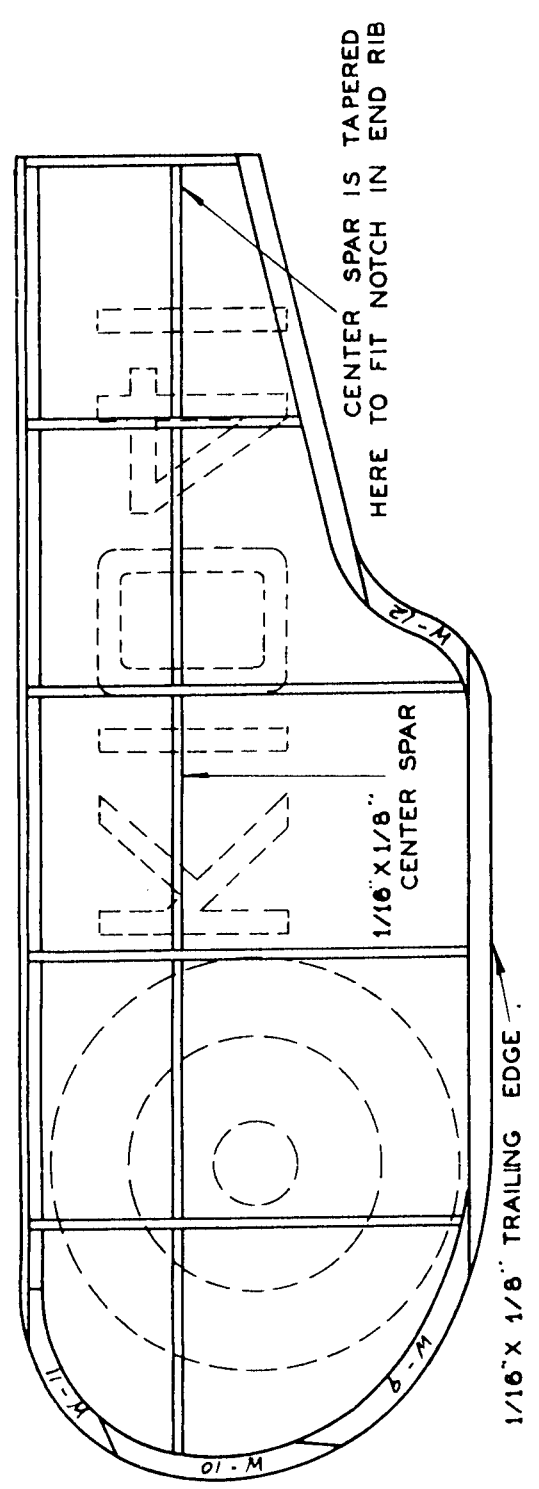
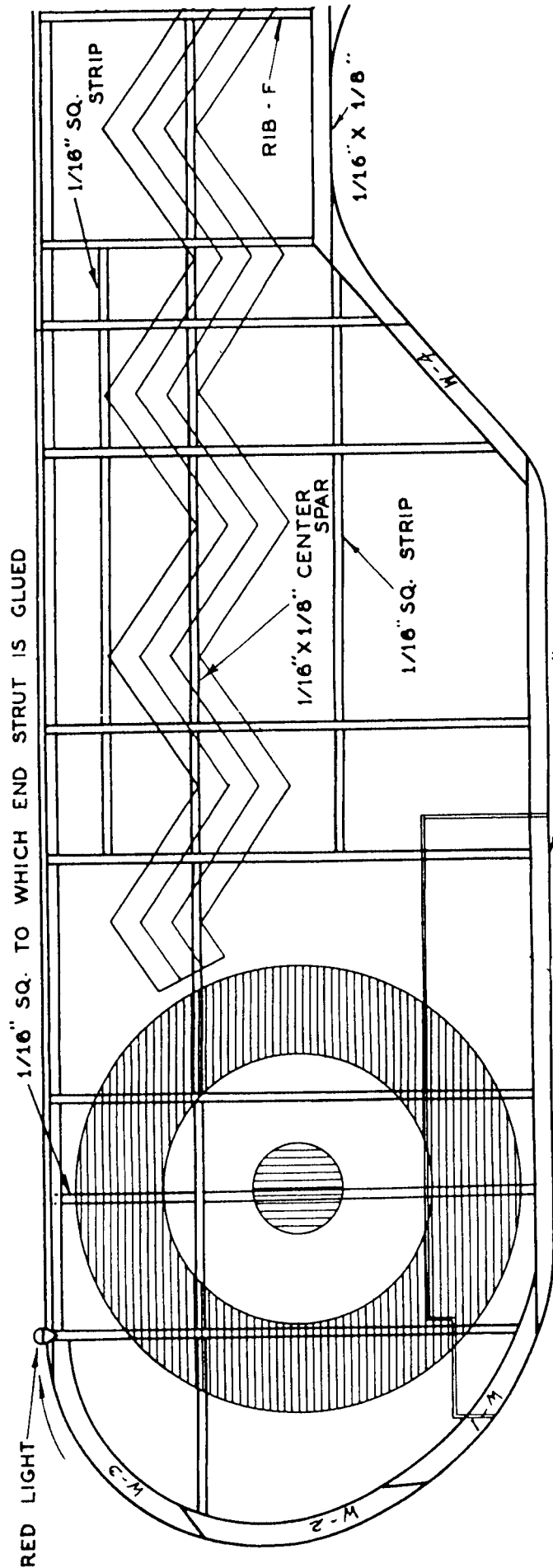

9/16" DIHEDRAL



GUN TROUGH
3/16" X 1/4" X 1-1/8"

VENTURI TUBE ON LEFT SIDE OF FUSELAGE ONLY.

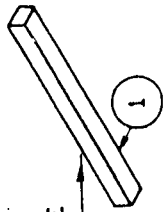

VENTURI TUBE
DETAIL

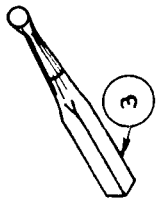
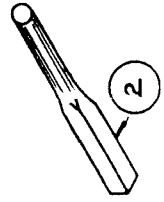

JOSEPH STAIRS Q
1/20/35

11/18/35

Ally Knoch

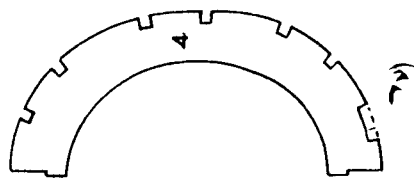
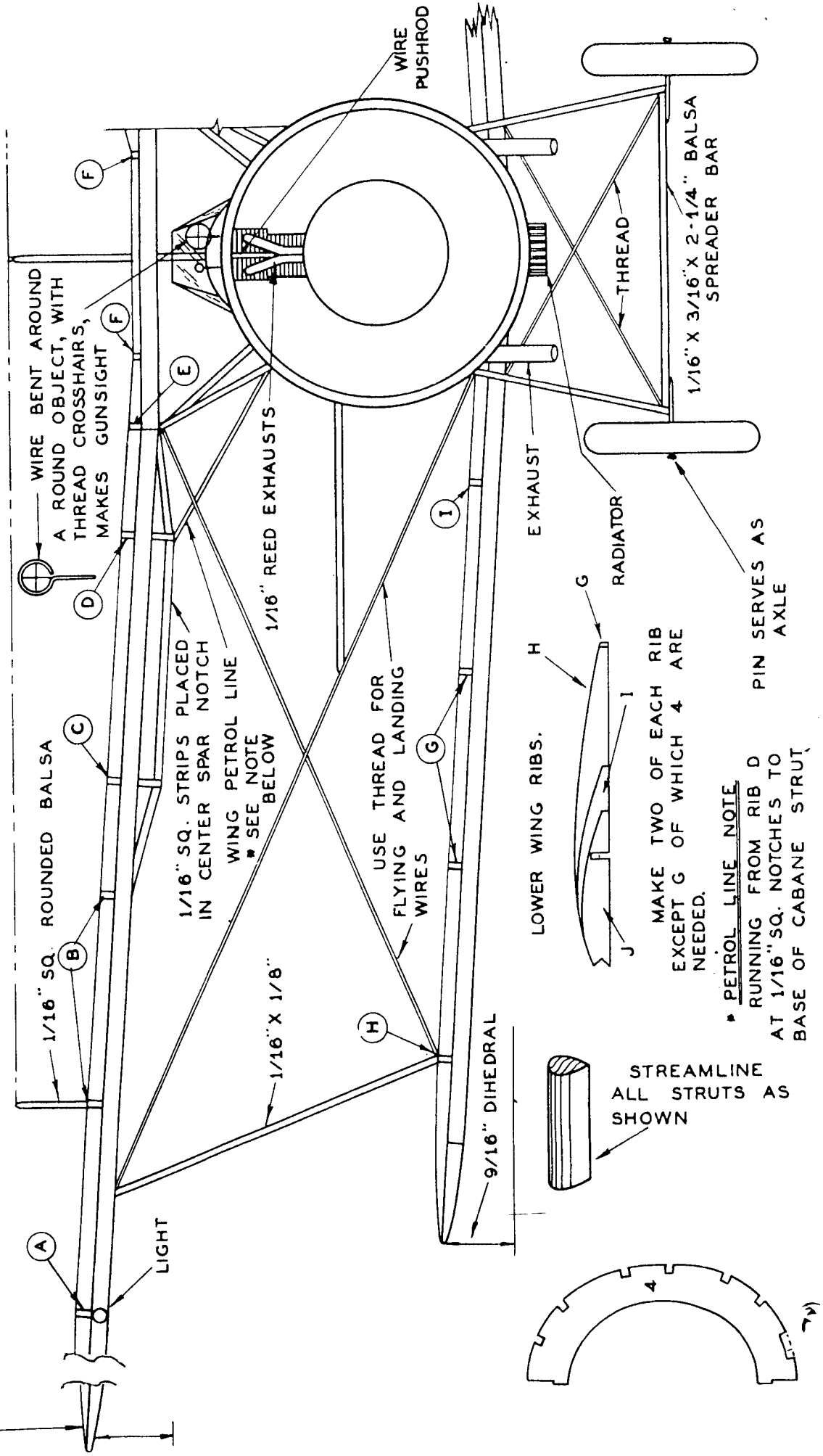

STREAMLINE
ALL STRUTS AS
SHOWN

MAKE TWO OF EACH RIB
EXCEPT G OF WHICH 4 ARE
NEEDED.

PETROL LINE NOTE
RUNNING FROM RIB D
AT 1/16" SQ. NOTCHES TO
BASE OF CABANE STRUT

PIN SERVES AS
AXLE