

BANANA OIL A STRIP OF BLACK TISSUE
HERE TO SHOW AILERON

LEADING EDGE IS
SANDED ROUND AS
SHOWN ABOVE.

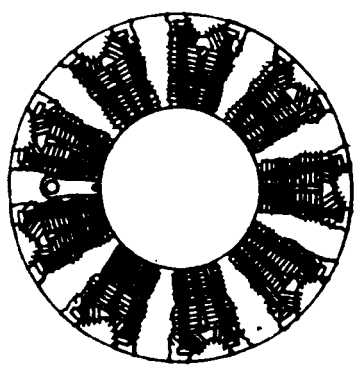
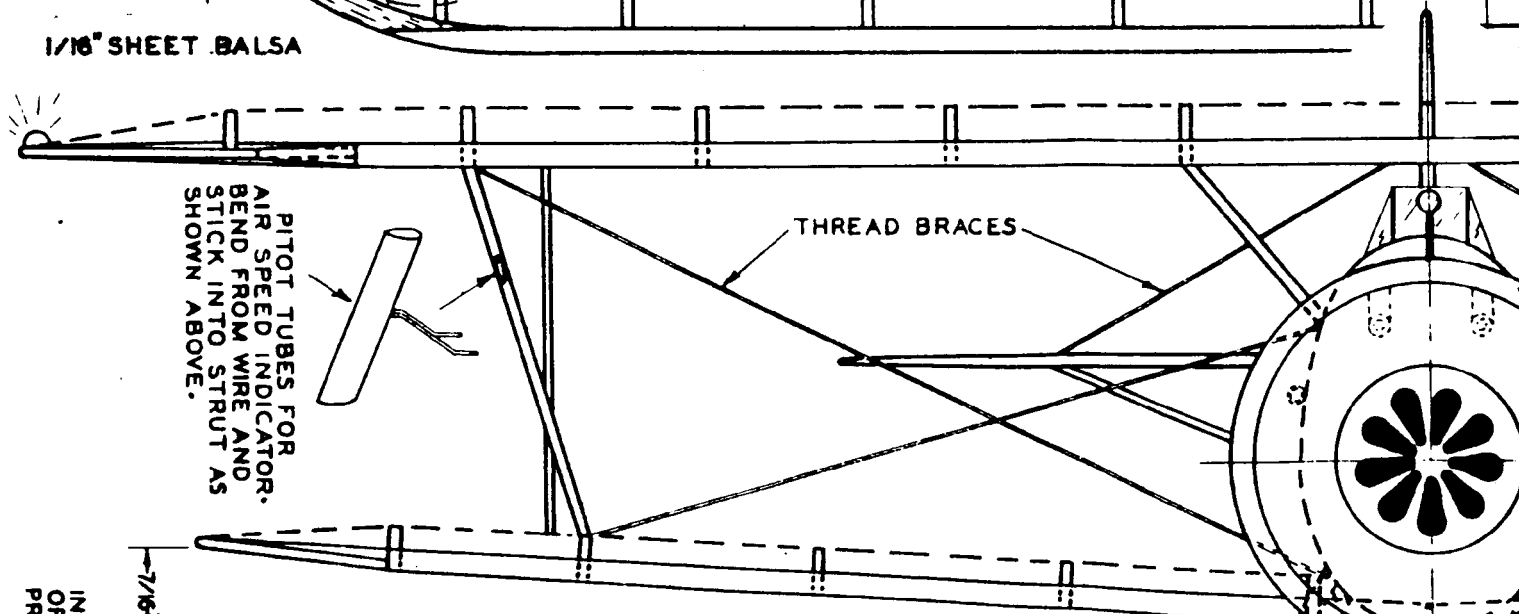
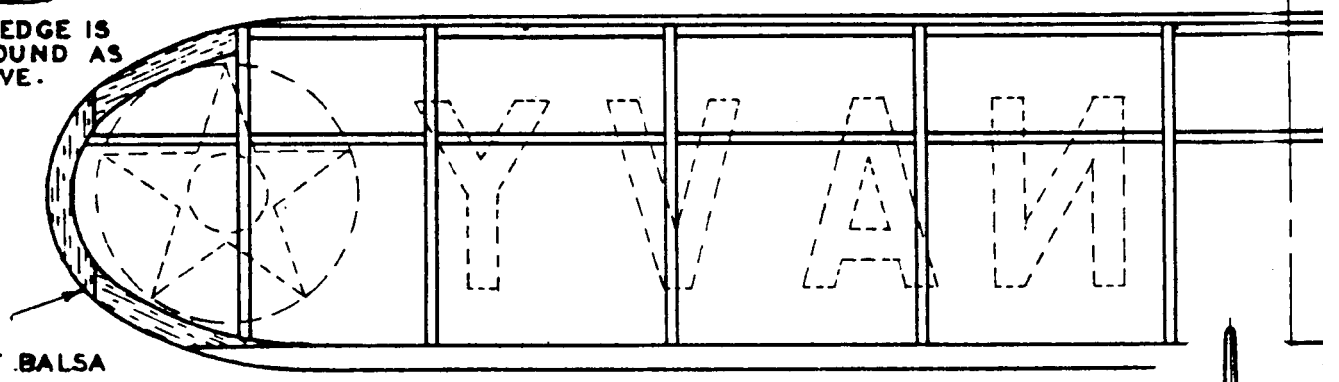

CUT ABOVE MOTOR DESIGN
FROM PLAN & STICK TO THE
FRONT OF COWLING.

COLOR SCHEME

LOWER & UNDER SIDE OF TOP
WING - WHITE.
TOP OF UPPER WING - YELLOW.
RUDDER & UNDERSIDE OF
ELEVATOR - WHITE.
TOP OF ELEVATOR - YELLOW
COWLING & STRUTS - ALUM.
FUSELAGE - WHITE.

NOTE: IF DESIRED MODEL
MAY BE DOPED USING COMET
NU-DOPE. ALL COLORS ARE
SOLD BY COMET DEALERS.
IF MODEL IS DOPED SUB-
STITUTE ALUMINUM FOR
WHITE.

FUSELAGE MAY BE GRAY
INSTEAD OF ALUMINUM. A BIT
OF BLACK IN WHITE DOPE WILL
PRODUCE GRAY.

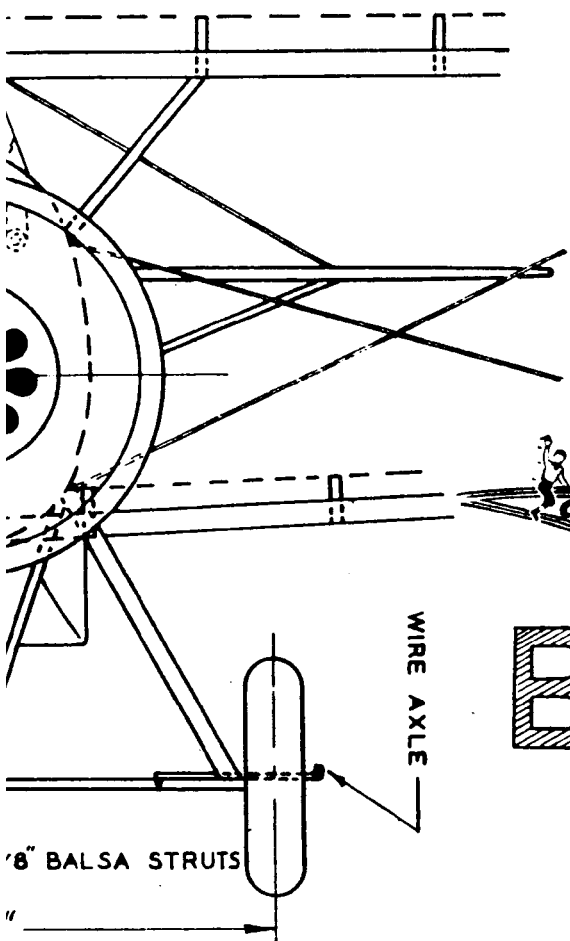
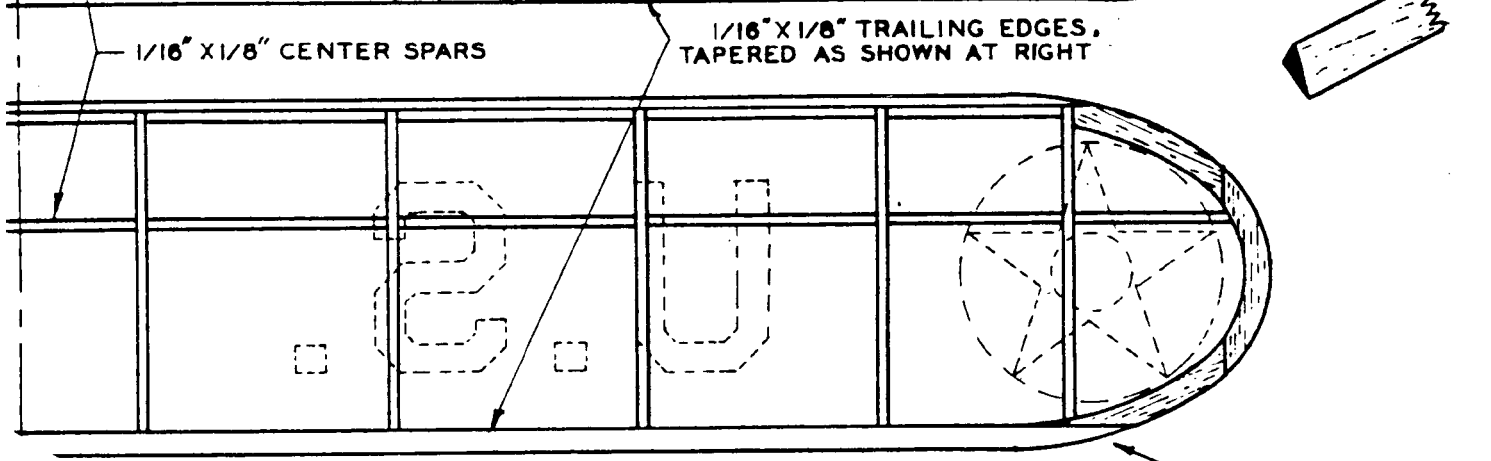

BALSA SEAT

ACTUAL PATTERN



PAPER

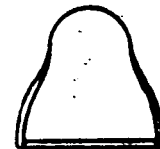

DO NOT INSTALL SEAT IF MODEL IS TO BE FLOWN AS IT INTERFERES WITH RUBBER STRANDS.



U.S. NAVY

BOEING FIGHTER

F4B-4

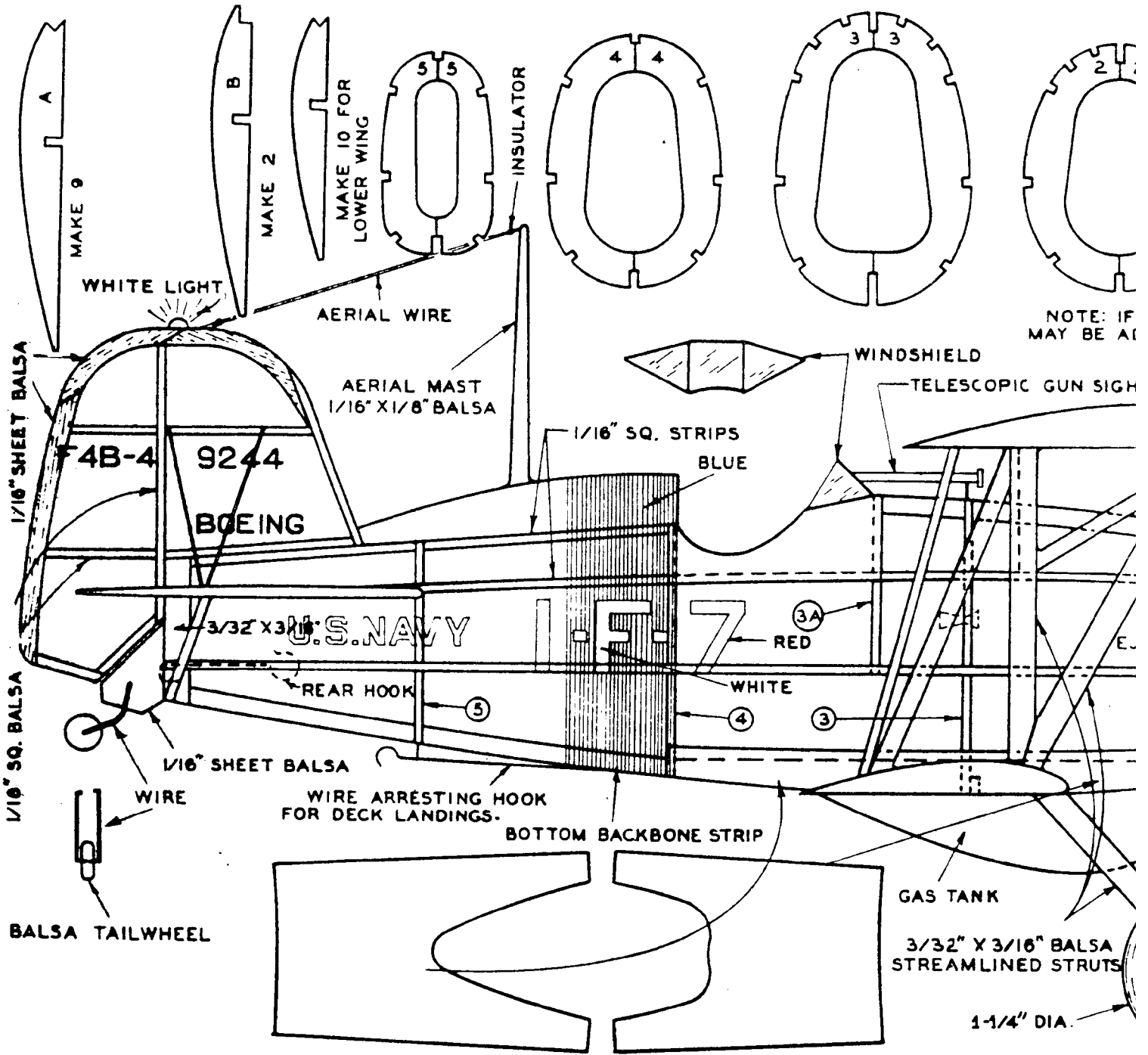

NOTE: IF
MAY BE AI

CUT ABOVE SHAPES FROM PLAN AND STICK TO BOTTOM OF FUSELAGE AS SHOWN ABOVE. LOWER WING IS ATTACHED TO BOTTOM OF FUSELAGE IN ONE PIECE. CRACK SPARS AT MIDDLE FOR DIHEDRAL ANGLE. COVER WING BEFORE IT IS ATTACHED TO FUSELAGE.

CUT FROM PLAN AND CEMENT TO THE TWO CURVED BALSASIDE PIECES.

AUXILIARY

TO BE USED O
BE FLOWN AS IT
CUT TWO SIDE PIECE
BALSAS. NOW MOISTEN
SHAPE BY HOLDING AC
ELECTRIC LIGHT BULB

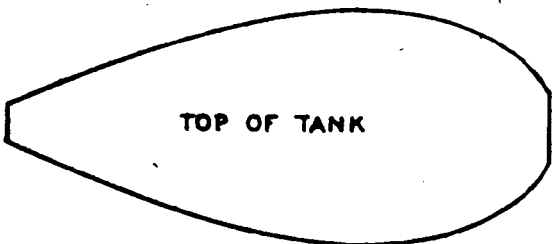

TOP OF TANK

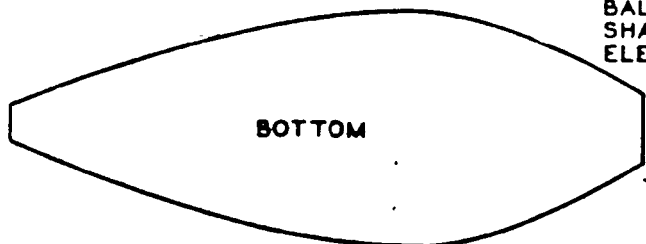

BOTTOM

NOTE: BEGIN CONSTRUCTION OF MODEL BY PINNING BACKBONE STRIPS DOWN ON PLAN. THESE ARE CUT FROM THE PRINTED BALSASHEET. NEXT CUT OUT FORMERS AND CEMENT TO BACKBONE STRIPS. A 1/16\"/>

1/16" SQ. STRINGERS GO INTO NOTCHES

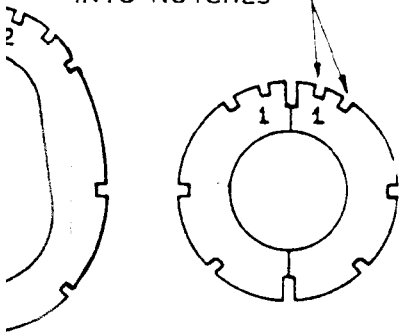

DESIRED MORE STRINGERS ADDED TO FUSELAGE.

T-Round Balsa

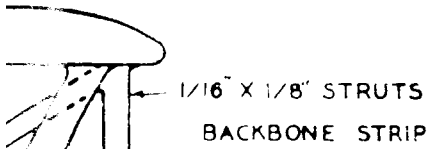

1/16" X 1/8" STRUTS
BACKBONE STRIP

SHELL DEFLECTOR

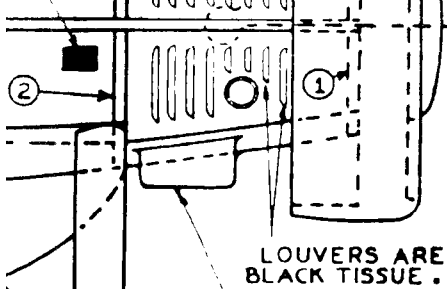

LOUVERS ARE BLACK TISSUE.

SHAPE FROM A 3/8" X 3/8" X 1/2" BLOCK. ROUND OFF ALL EDGES.

FOR FLYING USE THE 5 Balsa MACHINE CUT PROPELLER.

GAS TANK

ONLY IF MODEL WILL NOT ADDS UNNECESSARY WEIGHT. CUT FROM 1/16" SHEET Balsa AND BEND TO FIT AGAINST A LIGHTED

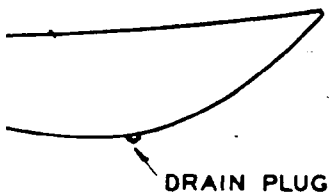

DRAIN PLUG

EXHIBITION PROP.

1/16" SHEET Balsa BLADES

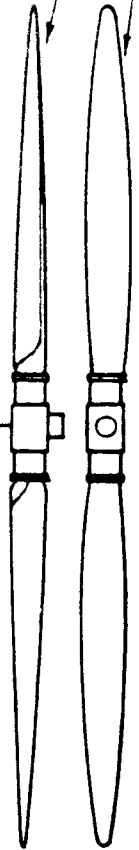

CUT INSTRUMENT BOARD FROM PLAN & STICK TO FORMER 3A.

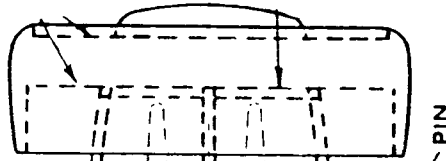

PIN

MACHINE GUNS MADE OF 3/32" ROUND Balsa

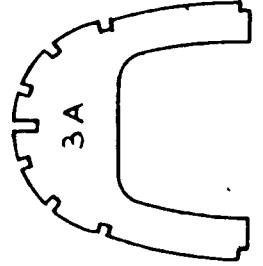

3A

VENTURI TUBE ON THIS SIDE ONLY

SHAPE HEADREST FROM A 3/8" X 1/2" X 2-1/4" BLOCK

1/16" SQ. Balsa

CUT COCKPIT COWL FROM PLAN & CEMENT TO FORMERS 3A & 4

